



People first. Safety always.

Document Title:

Fiberglass Crossarm-Dead End (5 ft. and 8 ft.) and Alley Arm (8 ft.)

Document Type:
Specification

Engineering Type
Material Specification

Document No.:
4300.50.351

Department:
Distribution Engineering

Version:
05

Effective Date:
Mar 24, 2026

For others, specify here

Shared document with: N/A

**Select the Departments impacted by the document (If apply)*

For others, specify here

Author

Rosalía Alverio González
Technical Specialist III, Distribution Standards & Materials

Signature and Date:

Mar 24, 2026

Reviewer

Rodolfo A. Flores Ortiz, PE (Lic. 27131)
Senior Engineer, Distribution Standards & Materials

Signature and Date:

Mar 24, 2026

Approver

Ricardo Castro Gómez, PE (Lic. 12135)
Manager, Distribution Standards & Materials

Signature and Date:

Mar 24, 2026

Management Approval (If apply)

Approver

Name
Position

Signature and Date:

Related/Referenced Documents

N/A

Version History

Version	Date	Revision
01	June 17, 2025	Initial Release. Items 008-82814, 008-82815, and 008-83421 were transferred from document 4350.155 and 4350.189 respectively. This document supersedes documents 4350.155 and 4350.189.
02	July 23, 2025	Modified Section 8: 8.2 (d) and 8.3 (e).
03	August 7, 2025	Modified Section 9 and changed Document number (Legacy Number: 4350.351) to new Engineering Records nomenclature number 4300.50.351.
04	September 19, 2025	Modified Section 7.1(e) and added Section 11.
05	March 24, 2026	Modified Section 6.3 and Table of Compliance.



Item Version History

Warehouse Catalog #	Asset Suite #	Version	Date
008-82814	82814	10	3/24/2026
008-82815	82815	10	3/24/2026
008-83421	83421	7	3/24/2026



1. Introduction

This is a general specification that covers the minimum requirements for the fiberglass crossarm dead end and the fiberglass crossarm alley arm to be used in the Distribution System in Puerto Rico. Further information will be provided by LUMA Energy at the time of order placement and will provide information on site specific conditions, quantity, and other requirements. This document includes the general characteristics of the equipment/material.

2. Literature

- 2.1. Descriptive and technical literature must be supplied by the vendor at time of bidding. This literature must include, but is not limited to, details of material, drawings, documented testing, and instructions for use and installation. The literature must be an official document from and certified by the manufacturer. **Failure to submit documents on time and duly certified by the manufacturer will cause bidder disqualification.**
- 2.2. If required by LUMA, final drawings and documentation shall be submitted by the vendor before the manufacturing and shipping process for approval.

3. Markings

- 3.1. Containers shall be marked outside with LUMA Energy's purchase order and item number.
- 3.2. Individual package(s) shall be clearly marked with manufacturer name and item information (part number, serial number, quantity, etc.).
- 3.3. Packaging labels and tags shall be waterproof.

4. Packaging

- 4.1. Each manufacturer shall define the number of poles per packages depending on the shipping on open platforms or closed trailers for delivery according to LUMA requirements.
- 4.2. At the time of bidding, the bidder must submit a drawing illustrating the proposed packaging configuration for the poles, including the quantity grouped accordingly and any other relevant details that demonstrate the packaging methodology.

5. Number Per Package (Logistics)

Each manufacturer should define the number of crossarm per package depending on the shipping on open platforms or closed trailers for delivery according to LUMA requirements or as requested by LUMA.

6. Acceptance Criteria

- 6.1. Test required: certified by external qualified laboratories.
- 6.2. Product shall be manufactured in accordance with the latest issue below (section 6.3). When conflicts occur between purchaser's specifications and the latest issue below, the purchaser's specification shall prevail.
- 6.3. Latest applicable codes, standards, and other regulations:

ASTM A153	Specification for Zinc Coating (Hot Dip) on Iron and Steel Hardware
ASTM A871	Standard Specification for High-Strength Low-Alloy Structural Steel Plate with Atmospheric Corrosion Resistance
ASTM D635	Standard Test Method for Rate of Burning and/or Extent and Time of Burning of Plastics in a Horizontal Position
ASTM 8019	Standard Test Methods for Determining the Full Section Flexural Modulus and Bending Strength of Fiber Reinforced Polymer Crossarms Assembled with Center Mount Brackets.
ASTM G154	Standard Practice for Operating Fluorescent Ultraviolet (UV) Light Apparatus for Exposure of Nonmetallic Materials

ASTM B85/B85M	Standard Specification for aluminum-alloy die castings.
ASTM D570	Standard Test Method for Water Absorption of Plastics
ASTM D2584	Standard Test Method for Ignition Loss of Cured Reinforced Resins
ASTM D3917	Standard Specification for Dimensional Tolerance of Thermosetting Glass-Reinforced Plastic Pultruded Shapes
ASTM D4385	Standard Practice for Classifying Visual Defects in Thermosetting Reinforced Plastic Pultruded Products
ASTM D578	Standard Specification for Glass Fiber Strands
ASTM D570	Standard Specification for Hot-Rolled Carbon Steel Sheet and Strip, Structural Quality
ANSI O5.3	Solid Sawn-Wood Crossarms and Braces - Specifications and Dimensions
ANSI B18.22.1	Type A Standard for washer dimensional requirements.
ASME B1.1	Unified Inch Screw Threads
UL 94	Classification and Flame-Retardant Plastic Materials
AWS D1.1	Structural Welding Code—Steel
RUS 1724e-151	Mechanical Loading on Distribution Crossarms
RUS 1724e-200	Design Manual for High Voltage Transmission Lines
ASCE-SEI-104	American Society of Civil Engineering
IEEE	Standard 4, and IEC 60060-1: Standard for High-Voltage Testing Techniques.

6.4. If any other standard different from the ones indicated in this document is used, the supplier must provide information showing compatibility with the required ones.

7. Description

The specifications are divided into two parts in the Technical Specifications and the Special Conditions. The Technical Specifications will include the material, design, types of poles to be used crossarm, types of crossarm, forces to be considerate, deflection, drawings, final approval before manufacture, labels and markings. The Special Conditions will include the crossarm color, mounting bracket, hardware, structural steel and accessories, and protective coating.

7.1. Technical Specifications

a. Material

The crossarm materials shall be composed of boron-free continuous glass fiber reinforcement by ASTM D578 and thermoset resin system. The crossarm material shall be self-extinguishing.

b. Design

1. The supplier is responsible for the design.
2. The bidder shall submit all the design parameters, either with the runs of the program he used for his analysis or other software to prove it. **Should they do not prove their design parameters, they will be automatically disqualified.**

c. Types of poles to be used crossarm

The crossarm base will be used for galvanized steel dodecagonal, square prestressed concrete, and fiber reinforce composites poles with heights from 35 ft. to 65 ft.

d. Types of crossarms

The crossarm provides crucial support to balance the tension of conductors at corners, along angled sections, and in areas with switch installations:

1. 5 ft. Crossarm: (Dead End)

- a. The crossarm shall feature four 13/16 in. diameter holes with a bolt sleeve positioned inside each hole.
- b. Looking at the crossarm from above, the distance from each end to the nearest hole shall be 6 in. (see top view in figure below).

- c. When viewed from the front, the distance from the end of the crossarm to the nearest hole shall be 4 in. (see front view in figure below).
- d. The crossarm's cross-section should be at least 4-5/8 in. by 3-5/8 in., or as otherwise determined by design requirements.
- e. A bracket shall be located at the center of the crossarm. The base that is shown in the drawing is for illustrative purposes only. The designer will have the task of making the mounting according to the specifications requested here. (See 8.2 e).

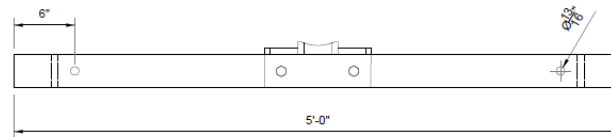

TOP VIEW

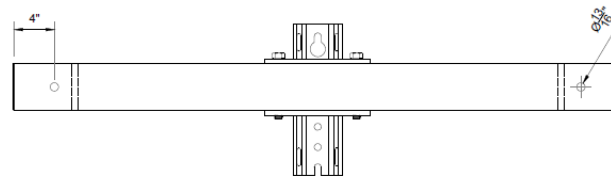

FRONT VIEW

2. 8 ft. Crossarm: (Dead End)

- a. The crossarm shall feature eight 13/16 in. diameter holes, with a bolt sleeve positioned inside each hole.
- b. Viewed from above, the crossarm has its first hole located 4 in. from each end. The second hole is located 2 ft.-9 in. from the end of the crossarm and is located 2 ft.-5 in. from the first hole.
- c. Viewed from the front, the first hole is 6 in. from each end of the crossarm. The second hole is 2 ft.-7 in. from the end of the crossarm and is located 2 ft.-1 in. from the first hole.
- d. The crossarm's cross-section should be at least 4-5/8 in. by 3-5/8 in., or as otherwise determined by design requirements.

- e. A bracket shall be located at the center of the crossarm. The base that is shown in the drawing is for illustrative purposes only. The designer will have the task of making the mounting according to the specifications requested here. (See 8.2 e).

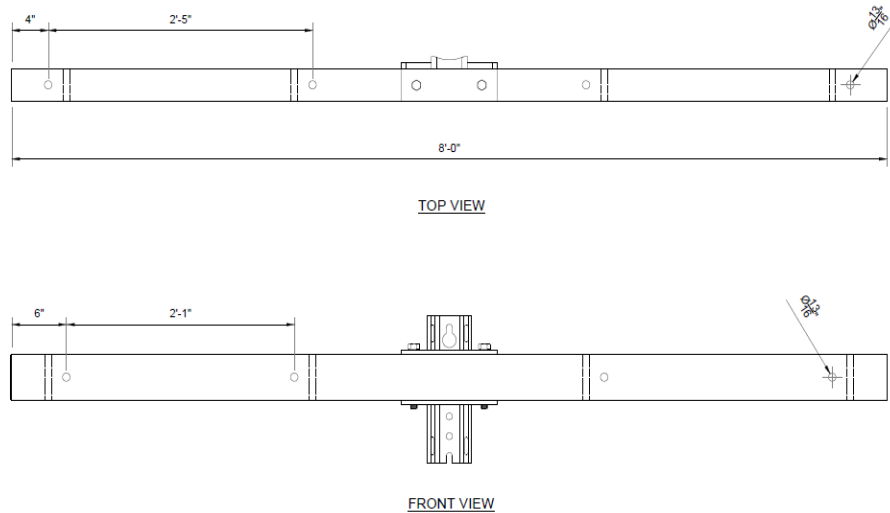

3. 8 ft. Alley Arm crossarm

- The alley arm crossarm is used to support overhead conductors when a displacement in the alignment of electrical power lines is required.
- The alley arm crossarm consists of one horizontal fiberglass beam with the support bracket located near one end and one diagonal fiberglass beam for reinforcement.
- The horizontal beam comprises five 13/16 in. diameter holes and a bolt sleeve positioned inside each hole.
- The support beam must have a 13/16 in. hole at the pole end that allows for mounting. This hole must align with the crossarm bracket above.
- The alley arm's cross-section for the horizontal and support beam should be at least 4-5/8 in. by 3-5/8 in., or as otherwise determined by design requirements.

f. Two possible cases for the construction of the crossarm are described below

1. **Case 1:** When viewed from the top (see figure below), the distance from the center of the mounting bracket to a first hole shall be 31 in. A second hole must be located 25 in. away from the first hole. A third hole shall be positioned 25 in. away from the second hole and 4 in. away from the end of the crossarm (unattached end). Therefore, the third hole will be located 81 inches from the center of the mounting bracket.

When viewed from the front, the distance from the end of the crossarm (attached end) to a first hole shall be 45 in., and a second hole must be located 44 in. away from the first hole (see figure below).

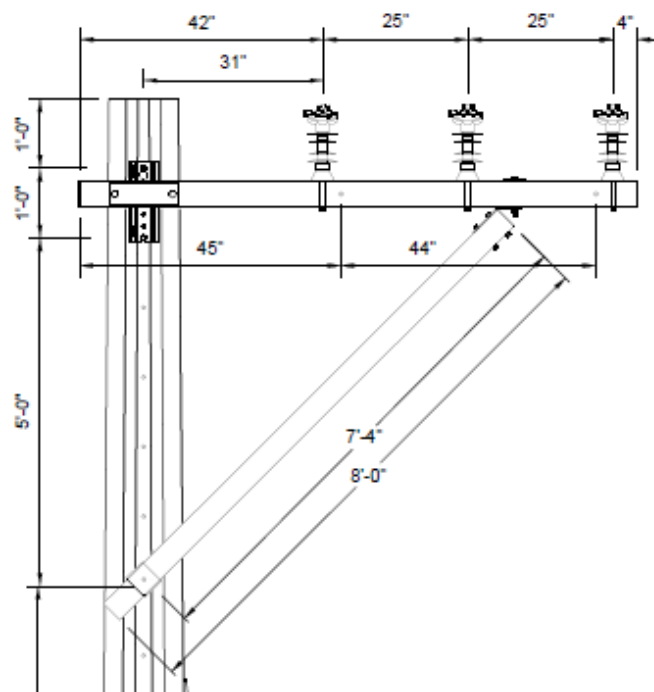

2. **Case 2:** As seen in the figure below, a hole shall be located 81 in. (6 ft.-9 in.) away from the center of the mounting bracket and 4 in. away from the end of the crossarm (unattached end).

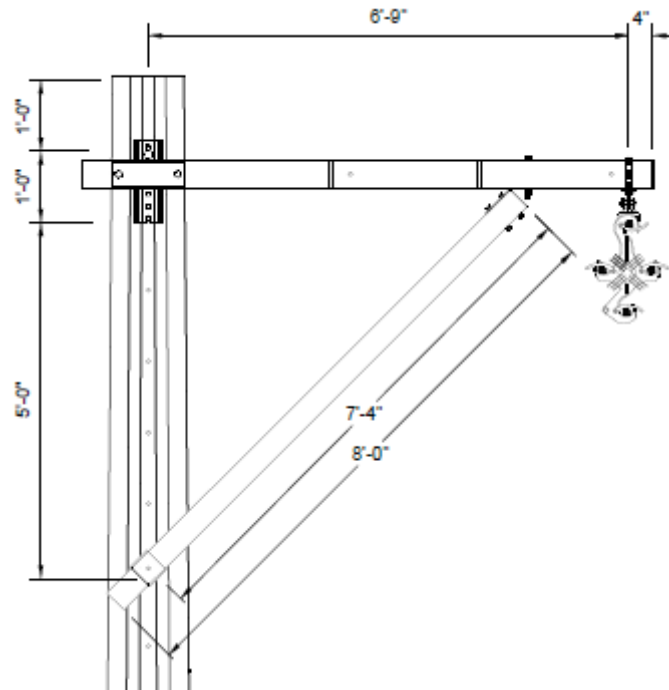

e. Forces to be considered

1. Loading on crossarm is the sum of the following forces when applicable: conductor tensions, weight of conductors, and the force of the wind on conductors and the crossarm.
2. Unbalanced loading can occur when the tensions in the conductors that are attached “into” and “out from” the crossarm assembly are unequal because of:
 - a. Change in conductor size or type.
 - b. Different installation tensions.
 - c. Unequal wind loading.
 - d. Different ruling spans.

3. Longitudinal, Vertical and Transversal Loads

Description	No. of Wires	Strength Rating Minimum Ultimate Longitudinal Load per wire (lbs.)	Ultimate Longitudinal Capacity (lbs.)	Ultimate Vertical Capacity (lbs.)	Ultimate Transversal Capacity (lbs.)
5 ft - DE	2	3,500	7,000	1,800	4,000
8 ft - DE	4	3,250	13,000	3,100	6,000
8 ft – AA-C1/C2	4	1,750	500	7,000	2,500

f. Deflection

Deflection is the displacement of the crossarm under load and is published in inches of displacement per 1000 lbs. of load applied.

g. Drawings

The bid proposal drawings shall include original documents with the following information:

1. General dimensions of all the structural components.
2. Weight for each crossarm (all accessories installed).
3. A bill of materials.
4. Details of all accessories including bolts, nuts, and washers to attach mounting bracket to the fiberglass beam, etc.

h. Final approval before manufacturing

1. Final design calculations shall be submitted before fabrication commences together with the shop drawing for LUMA approval.
2. After approval, one final set of drawings and design calculations in PDF format plus, a digital copy of drawings in AutoCAD 3D (DWG) shall be sent for our files.
3. All drawings shall include our purchase order number.

i. Labels and markings

1. Each crossarm shall have waterproof and legible identification labels.
2. The labels shall be 4 in. x 2 ½ in. approx. in dimension, stamped with letters.
3. The labels shall contain the following minimum information:

- a. Owner's name
- b. Warehouse Number
- c. Country
- d. Fabrication Date: MM/YY
- e. Batch Number
- f. RFQ Number or PO Number
- g. Model
- h. Dimension (L x W x H)
- i. Weight
- j. Manufacturer's Name

7.2. **Special Conditions**

a. Crossarm color

The crossarm color shall be gray.

b. Mounting bracket

- 1. The center mount bracket must be heavy duty type made of cast aluminum drilled and tapped.
- 2. Mounting holes must be 13/16 in. in diameter with 8 in. and 12 in. center to center spacing or, alternatively, with 12 in. and 16 in. center to center spacing.

c. Hardware, structural steel and accessories

- 1. Mounting bracket shall be made of 6061-T6 aluminum, hot-rolled steel, or welded structural steel.
- 2. All hardware, including mounting bracket, bolts, washers, and nuts shall be hot-dipped galvanized in accordance with ASTM A153. In addition, an open hole plug must be installed (included in this order).

d. Protective coating

- 1. The crossarm shall be treated with UV-resistant coating to protect against UV degradation.
- 2. The crossarm shall be tested for accelerated weathering and ultraviolet aging for 10,000 hours without any degradation of strength or modulus of elasticity (MOE), without deterioration of

color, and shall show no visual evidence of exposed glass fibers or other reinforcements when tested in accordance with ASTM G154.

3. UV coating shall have a minimum protective life expectancy of 40 years.

8. Delivery of material

- 8.1. The distribution crossarm will be delivered to the LUMA General Warehouse in Palo Seco (011), Puerto Rico, unless otherwise indicated and coordinated in another area provided by the company.
- 8.2. LUMA may take delivery at a designated location with the delivery carrier's equipment. The manufacturer shall coordinate with LUMA to ensure smooth and efficient delivery of the crossarm.
- 8.3. LUMA shall provide all labor, equipment, and materials for unloading the crossarm at the project site. A crossarm is considered delivered when it is lifted from the delivery carrier's trailer or semi-trailer.

9. Failure to meet the specification and guarantee

- 9.1. In the event that any equipment fails to comply with the warranties and requirements of these specifications within the period proposed or indicated, it shall be at the option of the LUMA representative to accept the material or reject it and instruct the manufacturer to proceed immediately to make such modifications or supply such new parts as may be necessary to bring it into compliance with the warranties and requirements.
- 9.2. All costs of supplying and installing new parts due to non-compliance of material with warranties and other specification requirements shall be the responsibility of the manufacturer.

10. Inspection

- 10.1. Upon inspection of incoming equipment/material, the purchaser reserves the right to refuse product shipments and to determine the acceptability or rejection of the product received. The supplier shall be liable for all costs incurred for a product that is rejected.
- 10.2. The acceptance of any equipment/material shall in no way relieve the vendor from his responsibility to meet all the requirements of this specification, and it would not prevent subsequent rejection if such equipment/materials were found later to be defective.

11. Download, handling, internal transport and storage

11.1. The procedure for storing crossarm includes several important precautions to ensure the integrity and safety of the material. Here are the key points:

a. Unloading with Forklifts

1. Required Equipment

- a. Forklift with a minimum capacity of 15,000 lb. (recommended)
- b. Forks in good condition, with appropriate length according to the pile size.
- c. Sturdy and resistant piles for proper load distribution, minimum height (5 ft).

2. Fork Length According to Pile Size

- a. For piles shorter than 10 ft, use 5 ft forks.
- b. For piles longer than 10 ft, use 8 ft forks.
- c. The forks must extend at least 60% of the pile's length.

3. Unloading Procedure

- a. Slowly insert the forks until 60% of the pallet is through.
- b. Lift the load in a controlled manner, without sudden movements.
- c. Remove the stack from the vehicle and position it on a flat and stable surface outside the forklift.
- d. Lower the load carefully.
- e. Re-take the stowage in the longitudinal direction (the longer one), ensuring it is centered over the forks.
- f. Move the load to the designated storage area following the established routes.

4. Precautions

- a. Never lift more than one stack at a time.
- b. Avoid sharp turns with the load raised.
- c. Dragging pallets with the forks is prohibited.
- d. Restrict unauthorized personnel access in the maneuvering area.

b. Internal Transport

- a. Keep the crossbars in a **horizontal position**, balanced and supported on the entire surface of the stacking.
- b. Ensure that the weight is distributed between both forks.
- c. Avoid bumps, unevenness, or irregular surfaces.

c. Storage

1. Minimum conditions

- a. The crossarms should only be placed at floor level, on pallets, wooden bases, or trestles that ensure a minimum height of 5 inches from the ground.
- b. It is prohibited to store them on high or elevated surfaces (metal racks, platforms, double pallets, or other structures).
- c. Storage areas must be clearly defined, organized, and free of machinery traffic that could cause accidental impacts.
- d. Direct contact of the crossarms with harder materials or elements that could cause scratches, cracks, or breakages on their surface should be avoided.

2. Environmental protection

- a. Cover the crossarms with breathable plastic tarps or store them indoors to protect them from moisture, rain, dust, and direct sunlight.
- b. Keep them away from aggressive chemical substances such as acids, solvents, or fuels.

Although the FRP material has high resistance to UV radiation, chemical agents, and external environmental conditions, it is recommended to keep the crossarms as protected as possible before installation. Proper protection during storage prolongs the product's lifespan and ensures better performance in service.

12. Proposal Information

12.1. Submitted proposals must include:

- a. Technical information, drawings, and tests.
- b. Table of Compliance completed by the bidder with reference (see Appendix 1).

13. Table 1: Warehouse and Asset Suite Identification Number

Crossarm Type	Warehouse Catalog #	Asset Suite #
5 ft. Crossarm-DE	008-82814	82814
8 ft. Crossarm-DE	008-82815	82815
8 ft. Alley Arm	008-83421	83421

DE: DEADEND

Appendix

Appendix 1: Table of Compliance

Line	Description	Pass/Fail (P / F)	Comments
Industry Standards	The Proponent complies with the industry standards established in the specification document (ANSI, ASTM)		
	ASTM G154 / ASTM D578		
	UL 94		
Literature	Technical Information		
	Drawings		
	Descriptive and technical literature must be supplied by the vendor at time of bidding. This literature must include, but is not limited to, details of material, drawings, documented testing, and instructions for use and installation. The literature must be an official document from and certified by the manufacturer. Failure to submit documents on time and duly certified by the manufacturer will cause bidder disqualification.		
Material	ASTM D578 and thermoset resin system.		
Design	The bidder shall submit all the design parameters, either with the runs of the program he used for his analysis or other software to prove it. Should they do not prove their design parameters, they will be automatically disqualified.		
Types of Crossarm	5 ft.-DE- The crossarm shall feature four 13/16" diameter holes with a bolt sleeve positioned inside each hole. Looking at the crossarm from above, the distance from each end to the nearest hole shall be 6" (see top view in figure below). When viewed from the front, the distance from the end of the crossarm to the nearest hole shall be 4" (see front view in figure below). The crossarm's cross-section should be at least 4-5/8" by 3-5/8", or as otherwise determined by design requirements. A bracket shall be located at the center of the crossarm. The base that is shown in the drawing is for illustrative purposes only. The designer will have the task of making the mounting according to the specifications requested here. (See 8.3 b).		
	8-Ft-DE- The crossarm shall feature eight 13/16" diameter holes, with a bolt sleeve positioned inside each hole. Viewed from above, the crossarm has its first hole located 4" from each end. The second hole is located 2'-9" from the end of the crossarm and is located 2'-5" from the first hole. Viewed from the front, the first hole is 6" from each end of the crossarm. The second hole is 2'-7" from the end of the crossarm and is located 2'-1" from the first hole. The crossarm's cross-section should be at least 4-5/8" by 3-5/8", or as otherwise determined by design requirements. A bracket shall be located at the center of the crossarm. The base that is shown in the drawing is for illustrative purposes only. The designer will have the task of making the mounting according to the specifications requested here. (See 8.3 b).		
	8-Ft-AA- The alley arm crossarm is used to support overhead conductors when a displacement in the alignment of electrical power lines is required. The alley arm crossarm consists of one horizontal fiberglass beam with the support bracket located near one end and one diagonal fiberglass beam for reinforcement. The horizontal beam comprises five 13/16 in. diameter holes and a bolt sleeve positioned inside each hole. The support beam must have a 13/16 in. hole at the pole end that allows for mounting. This hole must align with the crossarm bracket above. The alley arm's cross-section for the horizontal and support beam should be at least 4-5/8 in. by 3-5/8 in., or as otherwise determined by design requirements.		

Line	Description		Pass/Fail (P / F)	Comments
Forces	5 ft – DE	No. of Wires-2		
		Strength Rating Minimum Ultimate Longitudinal Load per wire (lbs.)-3,500		
		Ultimate Longitudinal Capacity (lbs.)-7,000		
		Ultimate Vertical Capacity (lbs.)-1,800		
		Ultimate Transversal Capacity (lbs.)-4,000		
	8 ft - DE	No. of Wires-4		
		Strength Rating Minimum Ultimate Longitudinal Load per wire (lbs.)-3,250		
		Ultimate Longitudinal Capacity (lbs.)-13,000		
		Ultimate Vertical Capacity (lbs.)-3,100		
		Ultimate Transversal Capacity (lbs.)-6,000		
	8 ft AA-C1/C2	No. of Wires-4		
		Strength Rating Minimum Ultimate Longitudinal Load per wire (lbs.)-1,750		
		Ultimate Longitudinal Capacity (lbs.)-500		
		Ultimate Vertical Capacity (lbs.)-7,000		
		Ultimate Transversal Capacity (lbs.)-2,500.		
NOTE:	At the time of the bidding, bidders must complete and include the information requested as described above. Any bidder who fails to complete this section will be immediately disqualified.			
Deflection	Deflection is the displacement of the crossarm under load and is published in inches of displacement per 1000 pounds of load applied.			
Color	Gray			
Mounting Bracket	The center must be heavy duty type made of cast aluminum drilled and tapped. Mounting holes at mounting plate must be 13/16 in. in diameter with 8 in. and 12 in. center to center spacing or, alternatively, with 12 in. and 16 in. center to center spacing.			
Hardware, Structural Stee, and Accessories	Mounting bracket shall be made of 6061-T6 aluminum, hot-rolled steel, or welded structural steel. All hardware, including mounting bracket, bolts, washers, and nuts shall be hot-dipped galvanized in accordance with ASTM A153 and shall have a finger-free fit.			
Protective Coating	Shall be treated with UV-resistant coating to protect against UV degradation.			
	Shall be tested for accelerated weathering and ultraviolet aging for 10,000 hours without any degradation of strength or modulus of elasticity (MOE), without deterioration of color, and shall show no visual evidence of exposed glass fibers or other reinforcements when tested in accordance with ASTM G154.			
	UV coating shall have a minimum protective life expectancy of 40 years.			

NOTE: This table is only a checklist for reference. The compliance must be with the complete document. Filling out the table with “PASS” won’t be accepted as a compliance without the technical information required to certify it.











4300.50.351 Fiberglass Crossarm-Dead End (5 ft. and 8 ft.) and (Alley Arm 8 ft.)(3-24-2026)

Final Audit Report

2026-03-24

Created:	2026-03-24
By:	Rosalia Alverio (rosalia.alverio@lumapr.com)
Status:	Signed
Transaction ID:	CBJCHBCAABAAfIDVDfv9SyLmAGDNIOhtyWcLICUGhIPi

"4300.50.351 Fiberglass Crossarm-Dead End (5 ft. and 8 ft.) and (Alley Arm 8 ft.)(3-24-2026)" History

-  Document created by Rosalia Alverio (rosalia.alverio@lumapr.com)
2026-03-24 - 7:36:55 PM GMT
-  Document emailed to Rosalia Alverio (rosalia.alverio@lumapr.com) for signature
2026-03-24 - 7:37:01 PM GMT
-  Email viewed by Rosalia Alverio (rosalia.alverio@lumapr.com)
2026-03-24 - 7:37:36 PM GMT
-  Document e-signed by Rosalia Alverio (rosalia.alverio@lumapr.com)
Signature Date: 2026-03-24 - 7:38:40 PM GMT - Time Source: server
-  Document emailed to Rodolfo Flores (rodolfo.floresortiz@lumapr.com) for signature
2026-03-24 - 7:38:42 PM GMT
-  Email viewed by Rodolfo Flores (rodolfo.floresortiz@lumapr.com)
2026-03-24 - 7:39:55 PM GMT
-  Document e-signed by Rodolfo Flores (rodolfo.floresortiz@lumapr.com)
Signature Date: 2026-03-24 - 7:45:10 PM GMT - Time Source: server
-  Document emailed to Ricardo Castro (ricardo.castro@lumapr.com) for signature
2026-03-24 - 7:45:13 PM GMT
-  Email viewed by Ricardo Castro (ricardo.castro@lumapr.com)
2026-03-24 - 8:20:59 PM GMT
-  Document e-signed by Ricardo Castro (ricardo.castro@lumapr.com)
Signature Date: 2026-03-24 - 8:21:15 PM GMT - Time Source: server

✔ Agreement completed.

2026-03-24 - 8:21:15 PM GMT