



Document Title:  
**Arm for Lighting Fixture-15 ft. (Aluminum Truss)**

Document Type: **Specification**      Engineering Type: **Material Specification**      Document No.: **4402.018**

Department  
**Street Light Program**

Version:  
**02**

Effective Date:  
Oct 12, 2023

Shared document with: N/A

*\*Select the Departments impacted by the document*

**For others, specify here**

**Author**

Rosalía Alverio González  
Technical Specialist 3, Distribution Standards & Materials

Signature

Date

Oct 12, 2023

**Reviewer**

Rafel Torres Martinez PE  
Supervisor, Distribution Standards & Materials

Signature

Date

Oct 12, 2023

**Approver**

Ricardo Castro PE  
Manager, Distribution Standards & Materials

Signature

Date

Oct 12, 2023

**Management Approval (If apply)**

**Approver**

Name  
Position

Signature and Date

N/A

**Related/Referenced Documents**

N/A

**Document History**

Version	Date	Revision Comments
1	April 1, 2022	Initial Release.
2	August 2, 2023	Add cover page and modification Section 9.
3	October 3, 2023	General formatting changes in various sections and drawing.



Document Title: Arm for Lighting Fixture-15 ft.  
(Aluminum Truss)  
Document No.: 4402.018  
Department: Steet Light Program

## Item Version History

Warehouse Catalog #	Asset Suite #	Version	Date
026-82611	82611	2	10/3/2023



## 1. Introduction

This is a general specification that covers pole lighting arm 15 ft. long truss type aluminum to be used for street lighting on the distribution system in Puerto Rico. Further information will be provided by LUMA Energy at the time of order placement and will provide information on site specific conditions, quantity, and other requirements. This document includes the general electrical and mechanical characteristics of the equipment/material.

## 2. Special Requirements

Samples shall be furnished as requested by LUMA Energy. Vendors that have supplied this equipment/material to LUMA on previous orders will not have to furnish samples at bid opening. The equipment/material will be received at the LUMA's general warehouse (O11) at Palo Seco, Puerto Rico. Shipping will include transportation and unloading at the indicated warehouse.

## 3. Literature

Descriptive and technical literature must be supplied by the vendor at time of bidding. This literature may include, but is not limited to details of material, drawings, documented testing, and instructions for use and installation. Failure to submit documents on time will cause bidder disqualification. Evidence of LUMA Energy's approval of the equipment/material shall be supplied by the vendor if requested by LUMA Energy.

## 4. Markings

- 4.1. Containers shall be marked outside with LUMA Energy's purchase order and item number.
- 4.2. Packaging labels and tags shall be waterproof.

## 5. Compatible with

- 5.1. See Table 1 for compatible manufacturers and models.
- 5.2. These models are examples of the equipment/material described in this document and do not represent a preference. LUMA will evaluate equally any model not listed here during any acquisition event.

## 6. Packaging

All equipment/material shall be packaged and marked in such a way as to facilitate handling and protection from damage and that the receiving warehouse can readily

identify it and send it, in one complete unit, to a field location without opening crates or boxes to sort items and/or parts.

## **7. Number per package (Logistics)**

One (1) unit per box or as requested by LUMA.

## **8. Acceptance criteria**

8.1. Test required: Certified Load Resistance Tests.

8.2. Latest applicable codes, standards, and other regulations: AASHTO, AISI, AA, and ASTM.

a. All stainless-steel hardware as per AISI type 304.

## **9. Description**

This specification is for the purpose of the arm for lighting fixture poles to support the electrical distribution system. The specifications are divided into two parts in the Technical Characteristics and the Special Conditions. The Technical Characteristics will include the design, material, drawings, final approval before manufacture, and failure to meet guarantees. The Special Conditions will include the special arm requirements, arm member dimensions, upper arm member dimensions, lower arm member dimensions, and arm clamp descriptions.

### **9.1. Technical Characteristics**

#### **a. Design**

The supplier is responsible of the design. The bidder will have to deliver the final computations and all design parameters considered. If the design was performed by a computer program, the supplier shall submit the runs generated by the program.

#### **b. Material**

1. The arm member shall be manufactured from wrought aluminum tubing alloy, seamless preferred.
2. Tubing 6063-T6 aluminum.
3. Arm and pole clamps 6061-T6 aluminum-alloy.
4. Arm termination shall be satin finish.
5. All welding shall be performed by the electrode inert gas shielding metal arc welding method and shall be free of cracks and porosity. The assembly shall be heat-treated after welding to a T6 temper for final mechanical strength in accordance with Aluminum Association standards.

#### **c. Drawings**

The supplier shall submit any applicable drawing for the bid proposal at PDF format and it shall include the following information:

1. General dimensions of all the structural components.
2. Weight for each arm.
3. A bill of material. (if applicable)
4. Details of all accessories (if applicable)

**d. Final Approval before Manufacture**

1. Final design calculations shall be submitted before fabrication commences together with the shop drawing for LUMA approval.
2. After approval, one final set of drawings and design calculations in PDF format plus a digital copy of drawings in AutoCAD 3D(.DWG) shall be sent for our files.
3. All drawings will include our order number, Warehouse Number, RFQ, or any identifying description.

**e. Failure to Meet Guarantees**

1. Should any piece of equipment fail to meet the guarantees and the requirements of these specifications within the time covered by the guarantee, it shall be optional to the Engineer to accept the material or reject it and direct the manufacturer to at once proceed to make alterations or furnish such new parts as may be necessary to make it meet the guarantees and requirements.
2. All expenses of furnishing and installing new parts by failure of the material to meet the guarantees and other requirements of the specifications will be manufacturer's responsibility.

**9.2. Special Conditions**

**a. Special Arm Requirements**

1. The arm shall be elliptical in cross-section.
2. Assembly shall sustain 160 miles per hour wind when supporting a 50 lb. luminaire and 80 lb. dead-load approximately, according to Luma Distribution System Design Manual.

**b. Arm member dimensions**

The elliptical upsweep of this truss member shall be 36 in. vertically measured from the center of the 6 in. arm clamp welded to the upper arm member to the center of the 2 in. diameter, 8 in. long slip fitter luminaire mount, and 15 ft. horizontally measured from the pole arm clamp face to the extended 6 in. at the slip fitter of the luminaire mount.

**c. Upper arm member dimensions**

1. Horizontal major axis welded at the center arm clamp and tapering to 3 in. outside diameter with 0.125 in. thickness tubing aluminum alloy into a 2 - 3/8 in. outside



diameter decreasing to a 2 in. outside diameter 8 in. long slip fitter luminaire mount.

2. The member elliptical upsweep shall have a bending radius of 15 ft. tangent to the lower arm member which radius shall be 9 ft. approximately.

**d. Lower arm member dimensions**

1. Horizontal major axis welded at the center of the lower arm clamp and tapering to 3 in. outside diameter with 0.125 in. thickness tubing aluminum - alloy into a 2 in. diameter.
2. The member elliptical upsweep shall have a bending radius of 10 ft. approximately shall coincide with upper member bending radius.
3. Vertical separation between upper and lower arm members shall be approx. 21 in. center to center of major ellipse axis at upper and lower arm clamps.

**e. Arm clamp descriptions**

The 6 in. wide and arm clamp shall be manufactured to match in secure conditions to the top of an aluminum pole with 6 in. diameter, in uniform outside diameter and shall be fastened by four (4) stainless steel hexagonal heavy-duty bolts ½ in. 13 NC-2 x 3 in. LG with corresponding two (2) flat washers, one (1) lock washer, one (1) hexagonal nut ½ in. 13 NC-2 for each clamp. (Included with order)

**10. Inspection**

The acceptance of any material or equipment shall in no way relieve the vendor from his responsibility to meet all the requirements of this specification, and it would not prevent subsequent rejection if such materials are found later to be defective.

**11. Proposal Information**

11.1. Submitted proposals must include:

- a. Technical information
- b. Table of Compliance completed by the bidder with reference. (See Appendix 1)

**12. Table 1: Warehouse and Asset Suite Identification Number**

Warehouse Number	Asset Suite	Compatible Manufacturer
026-82611	82611	Flagpoles Inc.

— End of Specification —



Document Title: Arm for Lighting Fixture-15 ft.  
(Aluminum Truss)  
Document No.: 4402.018  
Department: Steet Light Program

## Appendix



## Appendix 1: Table of Compliance

Line	Criteria	Description	Pass/Fail (P/F)	Comments
1	Specification	The Proponent complies with the corresponding specification document. (4402.018)		
2	Industry Standards	The Proponent complies with the industry standards established in the specification document. (AASHTO – AISI – AA – ASTM)		
3	Test required	Certified by External Laboratories.		
4	Special Arm Requirements	Arm and pole clamp 160 miles per hour wind when supporting a 50 lb. luminaire and 80 lb. dead-load approximately.		
5	Dimensions	Arm member: The elliptical upsweep of this truss member shall be 36 in. vertically measured from the center of the 6 in. arm clamp welded to the upper arm member to the center of the 2 in. diameter, 8 in. long slip fitter luminaire mount, and 15 ft. horizontally measured from the pole arm clamp face to the extended 6 in. at the slip fitter of the luminaire mount.		
		Upper arm member: Horizontal major axis welded at the center arm clamp and tapering to 3 in. outside diameter with 0.125 in. thickness tubing aluminum alloy into a 2 - 3/8 in. outside diameter decreasing to a 2 in. outside diameter 8 in. long slip fitter luminaire mount. The member elliptical upsweep shall have a bending radius of 15 ft. tangent to the lower arm member which radius shall be 9 ft. approximately.		
		Lower arm member: Horizontal major axis welded at the center of the lower arm clamp and tapering to 3 in. outside diameter with 0.125 in. thickness tubing aluminum - alloy into a 2 in. diameter. The member elliptical upsweep shall have a bending radius of 10 ft. approximately shall coincide with upper member bending radius. Vertical separation between upper and lower arm members shall be approx. 21 in. center to center of major ellipse axis at upper and lower arm clamps.		
		Arm clamp: The 6 in. (15.25 cm) aluminum alloy extruded pole and arm clamps shall be manufactured to match in secure conditions to the top of an aluminum pole 6 in. (15.28 cm) in uniform outside diameter and shall be fastened by four (4) stainless steel hexagonal HD bolts ½ in. (1.27 cm) 13 NC-2 x 3 in. (7.62 cm) lg with corresponding two (2) flat washers, one (1) lock washer, one (1) hexagonal nut ½ in. (1.27 cm) 13 NC-2 for each clamp. (Included with order)		
5	Material	The arm member shall be manufactured from wrought aluminum tubing alloy, seamless preferred.		
		Tubing 6063-T6 aluminum.		
		Arm and pole clamps 6061-T6 aluminum-alloy.		
		Arm termination shall be satin finish.		
		Welding to a T6 temper for final mechanical strength.		



# DISTRIBUTION ENGINEERING

DISTRIBUTION SPECIFICATION

TITLE:

ALUMINUM ARM 15 FT TRUST TYPE  
FOR USE IN ALUMINUM POLE

APPENDIX NO. 2  
DOCUMENT NO. 4402.018  
PAGE 1 OF 1 DATE OCT 03, 2023  
SUBMITTED ROSALIA ALVERIO GONZALEZ  
REVIEWED RAFAEL TORRES LIC 14593  
APPROVED RICARDO CASTRO LIC. 12135  
DIGITIZED VICTOR R. FEBRES LIC. 3412

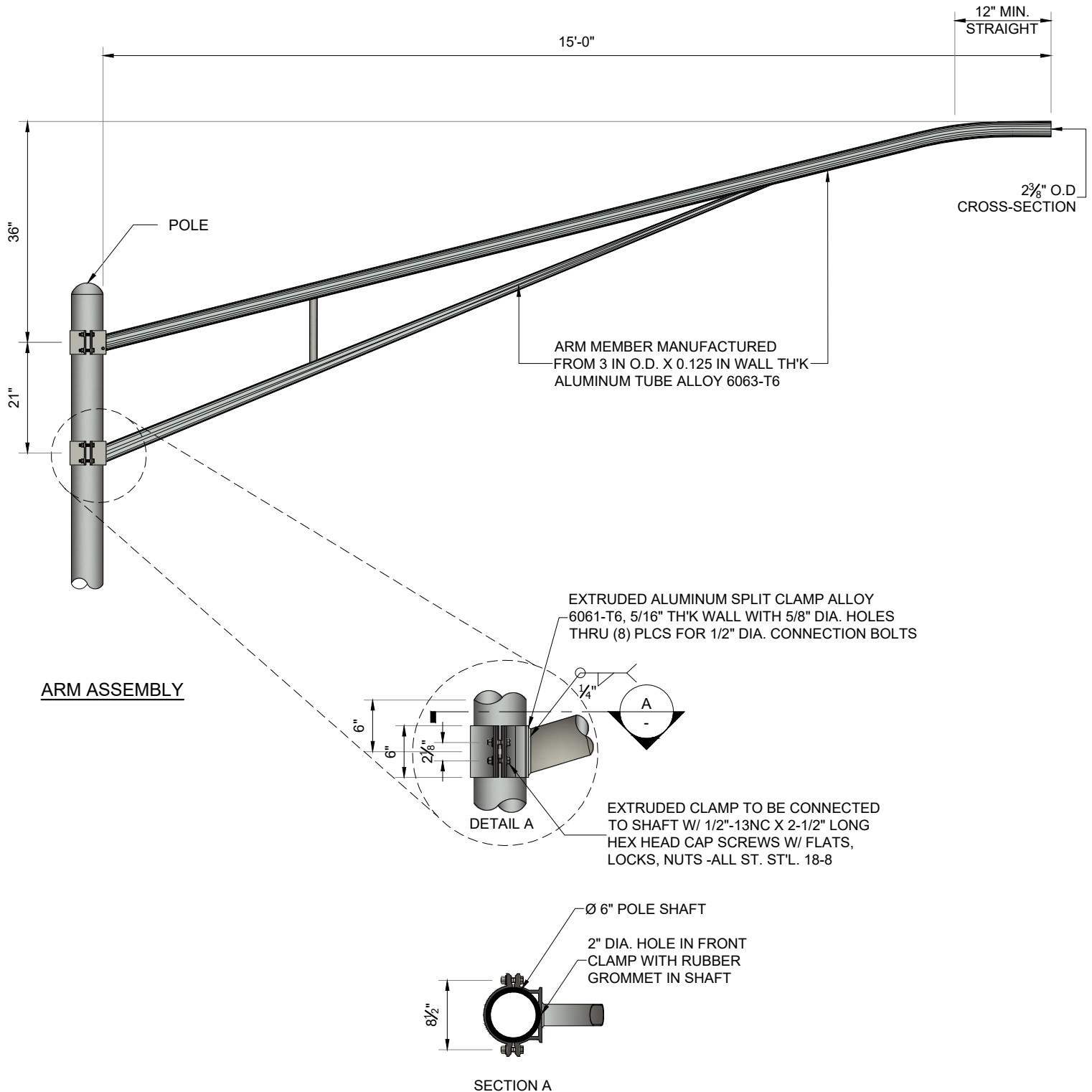











# 4402.018 Arm for Lighting Fixture-15 ft. (Aluminum Truss)(10-3-2023)

Final Audit Report

2023-10-12

Created:	2023-10-12
By:	Rosalia Alverio (rosalia.alverio@lumapr.com)
Status:	Signed
Transaction ID:	CBJCHBCAABAARxpQfwJ1TwClwzKLf0UIB7zTkMFXOp7

## "4402.018 Arm for Lighting Fixture-15 ft.(Aluminum Truss)(10-3-2023)" History

-  Document created by Rosalia Alverio (rosalia.alverio@lumapr.com)  
2023-10-12 - 2:41:37 PM GMT
-  Document e-signed by Rosalia Alverio (rosalia.alverio@lumapr.com)  
Signature Date: 2023-10-12 - 2:43:18 PM GMT - Time Source: server
-  Document emailed to Rafael Torres-Martinez (rafael.torresm@lumapr.com) for signature  
2023-10-12 - 2:43:20 PM GMT
-  Email viewed by Rafael Torres-Martinez (rafael.torresm@lumapr.com)  
2023-10-12 - 5:53:28 PM GMT
-  Document e-signed by Rafael Torres-Martinez (rafael.torresm@lumapr.com)  
Signature Date: 2023-10-12 - 5:53:39 PM GMT - Time Source: server
-  Document emailed to ricardo.castro@lumapr.com for signature  
2023-10-12 - 5:53:41 PM GMT
-  Email viewed by ricardo.castro@lumapr.com  
2023-10-12 - 6:41:11 PM GMT
-  Signer ricardo.castro@lumapr.com entered name at signing as Ricardo Castro Gómez  
2023-10-12 - 6:41:27 PM GMT
-  Document e-signed by Ricardo Castro Gómez (ricardo.castro@lumapr.com)  
Signature Date: 2023-10-12 - 6:41:29 PM GMT - Time Source: server
-  Agreement completed.  
2023-10-12 - 6:41:29 PM GMT