



Document Title:  
**Cast Aluminum Breakaway bases**

Document Type: **Specification**      Engineering Type: **Material Specification**      Document No.: **4402.008**

Department: **Street Light Program**      Version: **04**      Effective Date: **Jul 17, 2024**

**Shared document with: N/A**

*\*Select the Departments impacted by the document*

**For others, specify here**

**Author**

Rosalía Alverio González  
Technical Specialist 3, Distribution Standards & Materials

Signature

Date

Jul 16, 2024

**Reviewer**

Rodolfo Flores Ortiz PE (Lic. 27131)  
General Engineer, Distribution Standards & Materials

Signature

Date

Jul 16, 2024

**Approver**

Ricardo Castro PE (Lic. 12135)  
Manager, Distribution Standards & Materials

Signature

Date

Jul 17, 2024

**Management Approval (If apply)**

**Approver**

Name  
Position

Signature and Date

N/A

**Related/Referenced Documents**

N/A

**Document History**

Version	Date	Revision Comments
1	February 10, 2023	Add cover page and change document number
2	May 18, 2023	Drawing Modification
3	August 2, 2023	Document Modification
4	July 15, 2024	Section modification and drawing



Document Title: Cast Aluminum Breakaway bases.  
Document No.: 4402.008  
Department: Steet Light Program

## Item Version History

Warehouse Catalog #	Asset Suite #	Version	Date
026-00658	56209	12	7/15/2024



## 1. Introduction

This is a general specification that casts aluminum breakaway bases used on the distribution system in Puerto Rico. Further information will be provided by LUMA Energy at the time of order placement and will provide information on site specific conditions, quantity, and other requirements. This document includes the general electrical and mechanical characteristics of the equipment/material.

## 2. Special Requirements

Samples shall be furnished as requested by LUMA Energy. Vendors that have supplied this equipment/material to LUMA on previous orders will not have to furnish samples at bid opening. The equipment/material will be received at the LUMA's general warehouse (O11) at Palo Seco, Puerto Rico. Shipping will include transportation and unloading at the indicated warehouse.

## 3. Literature

Descriptive and technical literature must be supplied by the vendor at time of bidding. This literature may include, but is not limited to details of material, drawings, documented testing, and instructions for use and installation. Failure to submit documents on time will cause bidder disqualification. If required by LUMA, final drawings shall be submitted by the vendor before the manufacturing and shipping process for approval.

## 4. Compatible with

For compatible manufacturers and models, see Table 1. These models are examples of the equipment/material described in this document and do not represent a preference. LUMA will evaluate equally any models not listed here during any acquisition event.

## 5. Markings

- 5.1. Containers shall be marked outside with LUMA Energy's purchase order and item number.
- 5.2. Packaging labels and tags shall be waterproof.

## 6. Packaging

All equipment/material shall be packaged and marked in such a way as to facilitate handling and protection from damage and that the receiving warehouse can readily identify it and send it, in one complete unit, to a field location without opening crates or boxes to sort items and/or parts.

## 7. Number per package (Logistics)

Bundles of six (6) or eight (8) units per box or as requested by LUMA.

## 8. Acceptance criteria

8.1. Test required: Certified Load Resistance Tests.

8.2. Latest applicable codes, standards, and other regulations:

- a. AASHTO American Association of State Highway and Transportation Officials
- b. ASTM American Society for Testing and Materials
- c. ANSI American National Standards Institute
- d. AA Aluminum Association Standards

## 9. Description

Transformer breakaway base for 37 ft. long aluminum pole (40 ft. including luminaire arm). The assembly shall have the following configuration, as per LUMA Energy drawing no. 0260064D:

- a. Overall height: 17 in.
- b. Top surface: 13 in. - 15 in.
- c. Bottom surface: 14 in. - 16 in.
- d. The breakaway base wall thickness shall be  $\frac{1}{4}$  in. minimum.
- e. The top square surface shall be flat and shall have four (4) slotted holes 1 -  $\frac{1}{16}$  x 1 -  $\frac{5}{16}$  in. diameter with bolt circles of 15 in. maximum and 13 in. minimum.
- f. The bottom square surface shall be flat and have four (4) slotted holes 1 -  $\frac{1}{4}$  in. diameter with bolt circle of 16 in. maximum, as per drawing enclosed. The base shall be manufactured to support a structural configuration of a 37 ft. long aluminum pole with two (2) 15 ft. long truss type arms and luminaires.
- g. Electrical ground attachment: boss with  $\frac{1}{2}$  in. 13 NC - 2 hole tapped - thru shall be provided at the bottom square surface for electrical ground attachment.
- h. Connecting hardware: hot dip galvanized steel hardware for connecting base to aluminum pole shall be supplied with each base as follows: four (4) hexagonal head bolts 1 in. 8 NC - 2 x  $3\frac{3}{4}$  in. long, four (4) hexagonal nuts 1 in. 8 NC - 2, four (4) lock washers for 1 in. bolts, eight (8) flat washers 2 in. OD for 1 in. bolts.

- i. If there is any discrepancy between drawing and specification, the specification shall prevail.

#### 9.1. **Technical Characteristics**

##### **a. Design**

Complete assembly shall withstand a 160 miles per hour base wind with a luminaire wind load of 50 lb. and dead weight of 80 lb. according to Luma Distribution System Design Manual. Total supporting dead weight load capacity shall be 700 lb. minimum.

##### **b. Material**

1. Base assembly shall be manufactured 356-T6 aluminum alloy with cast section in accordance with the Aluminum Association (AA).
2. Access door: a non-removable access door shall be provided with dimension as shown in drawing enclosed. Shall be secured in place with a stainless steel piano hinge at the top and a locking device at the opposite side. Aluminum alloy material access door can be accepted. Other materials can be evaluated. This shall be in according to Aluminum Association (AA).
3. Galvanizing as per ANSI/ASTM A153.

##### **c. Drawings**

The supplier shall submit any applicable drawing for the bid proposal at PDF format and it shall include the following information:

1. General dimensions
2. Total Weight
3. A bill of material. (if applicable)
4. Details of all accessories (if applicable)

##### **d. Final Approval before Manufacture**

1. Final design calculations shall be submitted before fabrication commences together with the shop drawing for LUMA approval.
2. After approval, one final set of drawings and design calculations in PDF format plus a digital copy of drawings in AutoCAD 3D(.DWG) shall be sent for our files.
3. All drawings will include our order number, Warehouse Number, RFQ, or any identifying description.



**e. Failure to Meet Guarantees**

1. Should any piece of equipment fail to meet the guarantees and the requirements of these specifications within the time covered by the guarantee, it shall be optional to the Engineer to accept the material or reject it and direct the manufacturer to at once proceed to make alterations or furnish such new parts as may be necessary to make it meet the guarantees and requirements.
2. All expenses of furnishing and installing new parts by failure of the material to meet the guarantees and other requirements of the specifications will be manufacturer's responsibility.

**10. Inspection**

The acceptance of any equipment/material shall in no way relieve the vendor from his responsibility to meet all the requirements of this specification, and it would not prevent subsequent rejection if such equipment/materials were found later to be defective.

**11. Proposal Information**

- 11.1. Submitted proposals must include:
  - a. Technical information, tests, and drawings.
  - b. Table of Compliance completed by the bidder with reference. (See Appendix 1).

**12. Table 1: Warehouse and Asset Suite Identification Number**

Item	Description	Warehouse #	Asset Suite #	Compatible Manufacturer
1	Cast Aluminum Breakaway Bases	026-00658	56209	Akron Foundry Company

— End of Specification —



## Appendix



## Appendix 1: Table of Compliance

Line	Criteria	Description	Pass/Fail (P/F)	Comments
1	Specification	The Proponent complies with the corresponding specification document. (4402.008)		
2	Industry Standards	The Proponent complies with the industry standards established in the specification document. (AASHTO, ASTM, ANSI, and AA)		
3	Dimensions	Overall height: 17 in.		
		Top surface: 13 in. - 15 in.		
		Bottom surface: 14 in. - 16 in.		
		Base wall thickness shall be ¼ in. minimum		
4	Top square surface	Shall be flat and shall have four (4) slotted holes 1 - 1/16 x 1 - 5/16 in. diameter with bolt circles of 15 in. maximum and 13 in. minimum.		
5	Bottom square surface	Shall be flat and have four (4) slotted holes 1 - ¼ in. diameter with bolt circle of 16 in. maximum, as per drawing enclosed. The base shall be manufactured to support a structural configuration of a 37 ft. long aluminum pole with two (2) 15 ft. long truss type arms and luminaires.		
6	Electrical ground attachment	Boss with ½ in. 13 NC - 2 hole tapped -thru shall be provided at the bottom square surface for electrical ground attachment.		
7	Connecting hardware	Hot dip galvanized steel hardware for connecting base to aluminum pole shall be supplied with each base as follows: four (4) hexagonal head bolts 1 in. 8 NC - 2 x 3 ¾ in. long, four (4) hexagonal nuts 1 in. 8 NC - 2, four (4) lock washers for 1 in. bolts, eight (8) flat washers 2 in. OD for 1 in. bolts.		
8	Material	Base assembly shall be manufactured 356-T6 aluminum alloy with cast section in accordance with the Aluminum Association.		
		Galvanizing as per ANSI/ASTM A153.		
9	Weight	Indicate the total weight		

**NOTE: This table is only a checklist for reference. The compliance shall be with the complete document. Marking a PASS in the table won't be accepted as a compliance without the technical information required to certify it.**



# DISTRIBUTION ENGINEERING

DISTRIBUTION SPECIFICATION

TITLE:

**BREAKAWAY TYPE BASE FOR A 37'-0" ALUMINUM POLE**

APPENDIX NO. 3  
DOCUMENT NO. 4402.008  
PAGE 1 OF 1 DATE JUL 15, 2024  
SUBMITTED ROSALIA ALVERIO GONZALEZ  
REVIEWED RICARDO CASTRO LIC. 12135  
APPROVED RICARDO CASTRO LIC. 12135  
DIGITIZED VICTOR R. FEBRES LIC. 3412

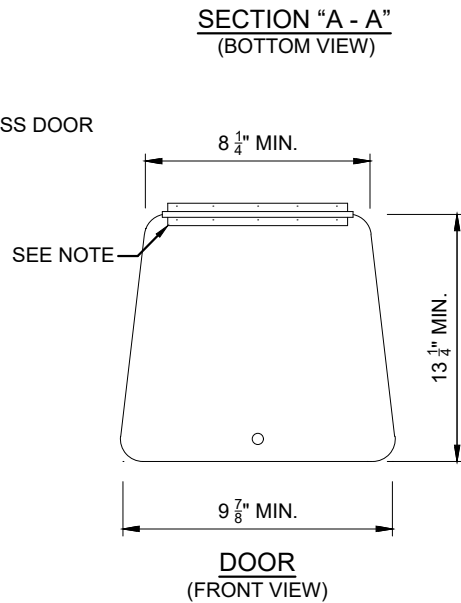
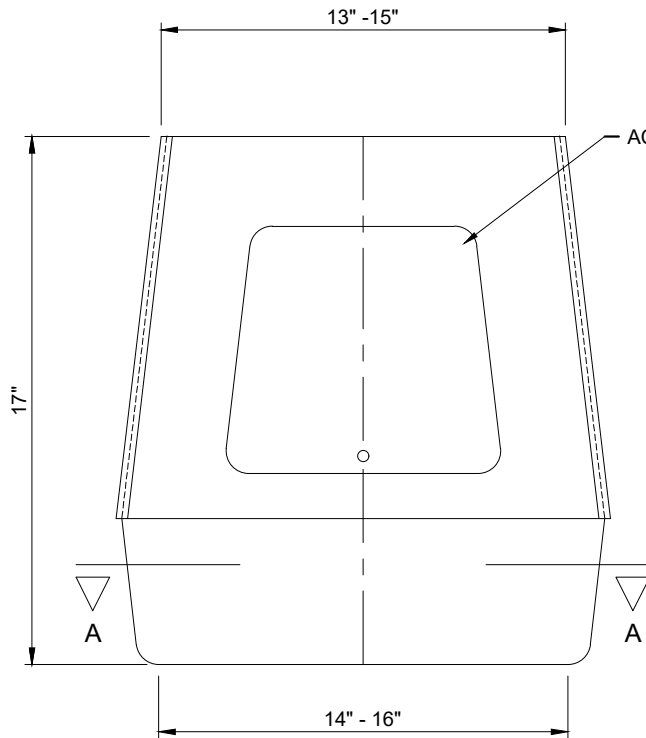
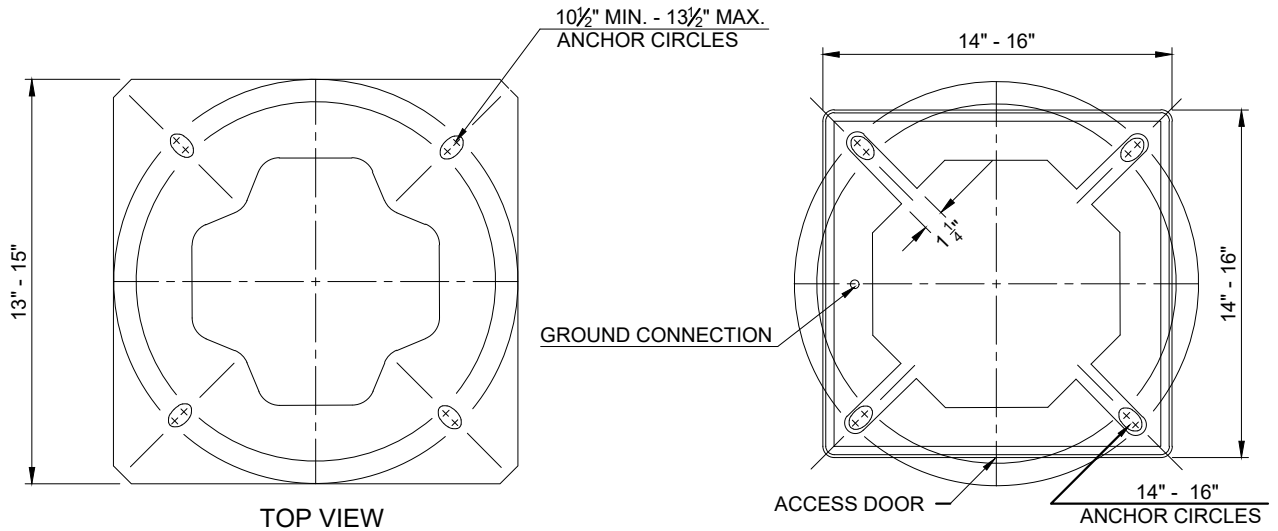

NOTE : A HINGE MAY BE USED IN THE  
BOTTOM PART OF THE DOOR.











# 4402.008 Cast Aluminum Breakaway Bases- (7-15-2024)

Final Audit Report

2024-07-17

Created:	2024-07-16
By:	Rosalia Alverio (rosalia.alverio@lumapr.com)
Status:	Signed
Transaction ID:	CBJCHBCAABAA3By98j-tYLKOWPoU4W0ChErIA-N7qIKk

## "4402.008 Cast Aluminum Breakaway Bases-(7-15-2024)" History

-  Document created by Rosalia Alverio (rosalia.alverio@lumapr.com)  
2024-07-16 - 8:14:11 PM GMT
-  Document emailed to Rosalia Alverio (rosalia.alverio@lumapr.com) for signature  
2024-07-16 - 8:14:17 PM GMT
-  Email viewed by Rosalia Alverio (rosalia.alverio@lumapr.com)  
2024-07-16 - 8:24:35 PM GMT
-  Document e-signed by Rosalia Alverio (rosalia.alverio@lumapr.com)  
Signature Date: 2024-07-16 - 8:24:43 PM GMT - Time Source: server
-  Document emailed to Rodolfo Flores (rodolfo.floresortiz@lumapr.com) for signature  
2024-07-16 - 8:24:48 PM GMT
-  Email viewed by Rodolfo Flores (rodolfo.floresortiz@lumapr.com)  
2024-07-16 - 8:25:26 PM GMT
-  Document e-signed by Rodolfo Flores (rodolfo.floresortiz@lumapr.com)  
Signature Date: 2024-07-16 - 8:26:06 PM GMT - Time Source: server
-  Document emailed to Ricardo Castro (ricardo.castro@lumapr.com) for signature  
2024-07-16 - 8:26:08 PM GMT
-  Email viewed by Ricardo Castro (ricardo.castro@lumapr.com)  
2024-07-17 - 2:06:38 PM GMT
-  Document e-signed by Ricardo Castro (ricardo.castro@lumapr.com)  
Signature Date: 2024-07-17 - 2:06:52 PM GMT - Time Source: server

✔ Agreement completed.

2024-07-17 - 2:06:52 PM GMT