



Document Title:

Aluminum Base Adapter for 8-12in Hole Spacing

Document Type:

Specification

Engineering Type

Material Specification

Document No.:

4350.349

Department

Distribution

Version:

01

Effective Date:

Feb 18, 2025

Shared document with: N/A

**Select the Departments impacted by the document*

For others, specify here

Document Title:

Author

Miguel J. Rios Lopez, PE (Lic. 16636)
General Engineer, Distribution Standards & Materials

Signature and Date

Feb 18, 2025

Reviewer

Rodolfo A. Flores Ortiz, PE (Lic. 27131)
General Engineer, Distribution Standards & Materials

Signature and Date

Feb 18, 2025

Approver

Ricardo Castro Gómez, PE (Lic. 12135)
Manager, Distribution Standards & Materials

Signature and Date

Feb 18, 2025

Management Approval (If apply)

Approver

Name
Position

Signature and Date

N/A

Related/Referenced Documents

N/A

Version History

Version	Date	Revision Comments
01	Feb. 18, 2025	Item created on 11/15/2022 and was revised five more times under document 4350.065. The Items under document 4350.065 were split out into new ones. Line Post Insulators remains on 4350.065 whereas Serrated Collar Stud Bolts were moved to 4350.350.



Document Title: Aluminum Base Adapter for
8-12in Hole Spacing
Document No.: 4350.349
Department: Distribution

Item Version History

Warehouse Catalog #	Asset Suite #	Version	Date
014-83736	83736	7	02/18/2025



1. Introduction

This is a general specification that covers the minimum requirements for the Aluminum Base Adapter to be used in the distribution system in Puerto Rico. Further information will be provided by LUMA Energy at the time of order placement and will provide information on site specific conditions, quantity, and other requirements. This document includes the general electrical and mechanical characteristics of the equipment/material.

2. Special Requirements

Samples shall be furnished as requested by LUMA Energy. Vendors that have supplied this equipment/material to LUMA in previous orders will not have to furnish samples at bid opening. The equipment/material will be received at LUMA's general warehouse (011) at Palo Seco, Puerto Rico. Shipping will include transportation and unloading at the indicated warehouse.

3. Literature

- 3.1. Descriptive and technical literature must be supplied by the vendor at time of bidding. This literature must include, but is not limited to, details of material, drawings, documented testing, and instructions for use and installation. **The literature must be an official document from and certified by the manufacturer.** Failure to submit documents on time and duly certified by the manufacturer will cause bidder disqualification.
- 3.2. If required by LUMA, final drawings and documentation shall be submitted by the vendor before the manufacturing and shipping process for approval.

4. Compatible with

For compatible manufacturer and model see Table 2. These models are examples of the equipment/material described in this document and do not represent a preference. LUMA will evaluate equally any model not listed here during any acquisition event.

5. Markings

- 5.1. Containers shall be marked outside with LUMA Energy's purchase order and item number.
- 5.2. Individual package(s) shall be clearly marked with manufacturer name and item information (part number, serial number, quantity, etc.).

5.3. Packaging labels and tags shall be waterproof.

6. Packaging

- 6.1. All equipment/material shall be packaged and marked in such a way as to facilitate handling and protection from damage and that the receiving warehouse can readily identify it and send it, in one complete unit, to a field location without opening crates or boxes to sort items and/or parts.
- 6.2. A list of all parts included in the container and/or package must be provided at the time of delivery so that the receiving personnel can verify that everything requested is present, avoiding any delay in the receiving process.

7. Number Per Package (Logistics)

Standard package indicated by the seller at bid opening or as required by LUMA.

8. Acceptance Criteria

- 8.1. Test required: certified by external qualified laboratories.
- 8.2. Product shall be manufactured in accordance with the latest issue below (section 8.3). When conflicts occur between purchaser's specifications and the latest issue below, the purchaser's specification shall prevail.
- 8.3. Latest applicable codes, standards, and other regulations:
- a. ASTM A153: For hot dip galvanizing steel components.
- 8.4. If any other standard different from the ones indicated in this document is used, the supplier must provide information showing compatibility with the required ones.

9. Description

- 9.1. The aluminum base adapter is used for installing line post insulators or other equipment on overhead distribution poles with hole spacing arrangement of 8" and 12" (20.32 and 30.48 cm).
- 9.2. Shall be C-channel type made of aluminum alloy 6061-T6. The strength properties of this alloy are tensile strength of 45,000 psi, and yield strength of 40,000 psi. Hot dip galvanized steel, in compliance with ASTM A153, could be accepted if aluminum alloy is not available. The body must be smooth with no sharp edge at all.
- 9.3. Shall be 15" (381 mm) approximate length, 4" (102 mm) wide, 2" (51 mm) high, and 1/2" (13 mm) thick. See Figure 1 and Table 1 for dimensions.
- 9.4. Shall have a 13/16" (20.6 mm) diameter keyhole or hole at the top, a second 13/16" diameter hole for insulator installation, followed by two 13/16" X 1-1/2" (21 X 38 mm) approximate length slots at the bottom. See Table 1 and Figure 1 for exact distance between holes, center to center, and edges A and D.

9.5. The base shall include a 3/4"-10 diameter serrated collar stud bolt with two lock washers and one hex nut. All hardware, including the bolt, shall be hot dip galvanized steel as per ASTM A 153. The bolt shall have a plain surface below the serrated collar for easy installation with a shoulder wrench. See Figure 2 and Table 1 for dimensions.

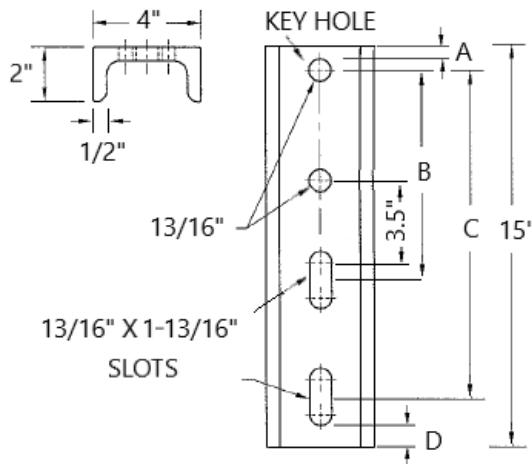

Figure 1

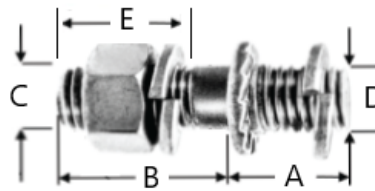

Figure 2

9.6. Table 1: Base Adapter and Serrated Collar Stud Bolt Dimensions

	A	B	C	D	E
Base (Figure 1)	0.812" (2.06 cm)	8" (20.32 cm)	12" (30.48")	0.875" (2.22 cm)	-
Bolt (Figure 2)	1-1/8" (2.86 cm)	1-3/4" (4.44 cm)	3/4" (1.90 cm)	3/4" (1.90 cm)	1-3/8" Min. Thread

10. Inspection

- 10.1. Upon inspection of incoming equipment/material, the purchaser reserves the right to refuse product shipments and to determine the acceptability or rejection of the product received. The supplier shall be liable for all costs incurred for a product that is rejected.
- 10.2. The acceptance of any equipment/material shall in no way relieve the vendor from his responsibility to meet all the requirements of this specification, and it would not prevent subsequent rejection if such equipment/materials were found later to be defective.



11. Proposal Information

11.1. Submitted proposals must include:

- a. Technical information, drawings, and tests.
- b. Table of Compliance completed by the bidder with reference (see Appendix 1).

12. Table 2: Warehouse and Asset Suite Identification Number

Warehouse Catalog #	Asset Suite #	Standard Package	Compatible Manufacturer & Model
014-83736	83736	Indicated by Seller	K-Line (KLMP-HWBK76) Hi-Tech Electrical (HTE LUMABRACKET-1)

— End of Specification —



Document Title: Aluminum Base Adapter for

8-12in Hole Spacing

Document No.: 4350.349

Department: Distribution

Appendix



Appendix 1: Table of Compliance

Line	Description	Pass/Fail (P / F)	Comments
1	Complies with document 4350.349.		
2	Industry Standards: ASTM A153 in case HDG be accepted.		
3	Tech. info., drawings, and tests provided.		
4	Aluminum Alloy 6061-T6		
5	C-Channel Type		
6	Dimensions: 15" (L) X 4" (W) X 2" (H) X 1/2" (T)		
7	Holes & slots arrangement as per Figure 1 and Table 1.		
8	Serrated collar stud bolt, 2 lock washers, and 1 nut included.		
9	Bolt measurements as per Figure 2 and Table 1.		

NOTE: This table is only a check list for reference. The compliance shall be with the complete document. Marking a PASS in the table won't be accepted as a compliance without the technical information required to certify it.











4350.349 Aluminum Base Adapter for 8-12in Hole Spacing (2-18-25)

Final Audit Report

2025-02-18

Created:	2025-02-18
By:	Miguel Rios (miguel.rioslopez@lumapr.com)
Status:	Signed
Transaction ID:	CBJCHBCAABAAexm7_nXrpLKMmaRvIXtcJSUqdVcfzSXZ

"4350.349 Aluminum Base Adapter for 8-12in Hole Spacing (2-18-25)" History

-  Document created by Miguel Rios (miguel.rioslopez@lumapr.com)
2025-02-18 - 12:27:15 PM GMT
-  Document emailed to Miguel Rios (miguel.rioslopez@lumapr.com) for signature
2025-02-18 - 12:27:20 PM GMT
-  Document e-signed by Miguel Rios (miguel.rioslopez@lumapr.com)
Signature Date: 2025-02-18 - 12:27:43 PM GMT - Time Source: server
-  Document emailed to Rodolfo Flores (rodolfo.floresortiz@lumapr.com) for signature
2025-02-18 - 12:27:45 PM GMT
-  Email viewed by Rodolfo Flores (rodolfo.floresortiz@lumapr.com)
2025-02-18 - 12:39:59 PM GMT
-  Document e-signed by Rodolfo Flores (rodolfo.floresortiz@lumapr.com)
Signature Date: 2025-02-18 - 12:43:10 PM GMT - Time Source: server
-  Document emailed to Ricardo Castro (ricardo.castro@lumapr.com) for signature
2025-02-18 - 12:43:11 PM GMT
-  Email viewed by Ricardo Castro (ricardo.castro@lumapr.com)
2025-02-18 - 2:27:21 PM GMT
-  Document e-signed by Ricardo Castro (ricardo.castro@lumapr.com)
Signature Date: 2025-02-18 - 2:27:29 PM GMT - Time Source: server
-  Agreement completed.
2025-02-18 - 2:27:29 PM GMT