	Document Title: <b>Polymer Braced Post Insulator 115 &amp; 230 kV</b>	
	Document Type: <b>Specification</b>	Engineering Type Equipment Specification
Department: <b>Transmission Engineering</b>	Version: <b>01</b>	Effective Date: <b>Nov 9, 2023</b>
<b>Shared document with: N/A</b>		

**Author**  
Koral Caro Rivera  
Technical Specialist 1, T&S Standards and Materials

**Reviewer 1**  
Leonardo Montes  
Engineer 2, T&S Standards and Materials

**Reviewer 2**  
Juan C Miranda  
Supervisor, Line Engineering Design

**Approver 1**  
Oscar Venegas  
Supervisor, Line Engineering Standards

Signature and Date  
  
[Koral Caro Rivera \(Oct 31, 2023 14:51 EDT\)](#)

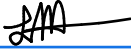
Signature and Date  
  
[Leonardo Montes Sanchez \(Nov 6, 2023 13:48 AST\)](#)

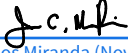
Signature and Date  
  
[Juan Carlos Miranda \(Nov 6, 2023 14:12 AST\)](#)

Signature and Date  
  
[Oscar E Venegas \(Nov 9, 2023 14:16 AST\)](#)

**Version History**

Version	Date	Revision
01	Nov 9, 2023	

## **1. General**

- 1.1. This specification describes the minimum requirements for the design, manufacturing, testing, and supply of silicone rubber composite braced insulators to be used in the transmission lines in Puerto Rico.
- 1.2. Further information will be provided by LUMA Energy at the time of order placement and will provide information on site conditions, quantity, and other requirements.

## **2. Specific Name**

- 2.1. Polymer Braced Post Insulator for Transmission System.

## **3. Basic Use**

- 3.1. The braced post insulator is used for vertical mechanical support and insulation on overhead transmission lines.

## **4. Special Requirements**

- 4.1. Samples shall be furnished if requested by LUMA.
- 4.2. LUMA may require One (1) unit properly labeled for testing and analysis.
- 4.3. Descriptive and technical literature shall be supplied if requested by LUMA.
- 4.4. They shall be required to show evidence of LUMA's approval of the equipment if requested.

## **5. Marking**

- 5.1. Each composite insulator shall bear a marking in accordance with ANSI Standards, identifying the following:
  - 5.1.1. Manufacturer's Name.
  - 5.1.2. Manufacturer's Catalog Number.
  - 5.1.3. Year of Manufacture.
  - 5.1.4. Specified Mechanical Load (S.M.L.).
- 5.2. The marking shall be legible and durable. The use of labels is not permitted.
- 5.3. Containers shall be marked outside with LUMA's purchase order number and code number.

## 6. Packaging / Labeling

- 6.1. All material and equipment shall be packaged and marked in such a way as to facilitate handling and protection from damage and that the receiving warehouse can readily identify it and send it, in one complete unit, to a field location without opening crates or boxes to sort items and/or parts.
- 6.2. Insulators shall be shipped in boxes or crates with units supported by end fittings. At least one intermediate support is required.
- 6.3. Handling instructions shall be shipped inside each box or crate.
- 6.4. Corona rings shall be packaged and shipped on separate compartments of the crate or box containing the insulators. Drawings showing the installation procedure and correct position of the corona ring shall be shipped inside the crate or box.
- 6.5. Crates or boxes walls shall be protected against rodents and be lined to protect insulators from dirt and dust.
- 6.6. Packaging labels and tags shall be waterproof. Clear weatherproof containers are required for each insulator. The containers shall be removable by hand.

## 7. Compatible with:

- 7.1. For compatible manufacturer and model see Section 12 Table 1.
- 7.2. These models are examples of the equipment/material described in this document and do not represent a preference. LUMA will evaluate equally any model not listed here during any acquisition event.

## 8. Number per package:

- 8.1. As requested by LUMA.

## 9. Acceptance Criteria

- 9.1. Latest applicable codes, standards, and other regulations:
  - 9.1.1. ANSI C29.1 Test Methods for Electrical Power Insulators.
  - 9.1.2. ANSI C29.11 Standard for Composite Suspension Insulators for Overhead Transmission Lines Test.
  - 9.1.3. ANSI C29.18: for composite line post insulators made of a fiberglass-reinforced resin matrix core, elastomeric material weather sheds and metal end fittings.
  - 9.1.4. ANSI 987 IEEE Guide for Application of Composite Insulators.
  - 9.1.5. CSA 411 .4 Composite Suspension Insulators for Transmission Applications.
  - 9.1.6. IEC 61109 Composite Insulators for AC Overhead Lines with a Minimal Voltage Greater than 1,000 volts, Definitions, Test Methods, and Criteria.
  - 9.1.7. ASTM A153 Zinc Coating (Hot-Dip) on Iron and Steel Hardware.

## 10. Description

- 10.1. Temperature & Humidity: The equipment supplied shall be adequate for an operating temperature range of 5°C to 40°C (41 to 104 °F), with humidity up to 100%.

- 10.2. The manufacturer's probable true values for the dry and wet low frequency flashover, and for the positive and negative critical impulse flashover shall include the corona ring effect and shall be in the range specified by Section 12 Table 1.
- 10.3. All brace post insulator assembly shall include the following parts and hardware: Suspension insulator, line post insulator, socket y-clevis and extension link.
- 10.4. All brace post insulator assembly shall be compatible and suitable to be attached following the dimensions describes on Section 13 Drawings.
- 10.5. LUMA requires corona rings for all insulators.
- 10.6. **Suspension Insulator**
  - 10.6.1. The composite suspension insulator design shall be long rod aerodynamic type design. The suspension insulator end fittings at the line end shall be terminated with an ANSI class 52-5 ball and at the grounded end with Y clevis.
  - 10.6.2. The manufacturer's probable true values for the dry and wet low frequency flashover, and for the positive and negative critical impulse flashover shall include the corona ring effect, and shall be in the range specified by Table I.
  - 10.6.3. If a corona ring is necessary, the manufacturer's probable true values for the dry and wet low frequency flashover and for the positive and negative critical impulse flashover shall include the corona ring effect, and shall be in the range specified by Table I.
- 10.7. **Line Post Insulator**
  - 10.7.1. Line post insulators line end fitting shall be a two-hole blade (also called drop tongue line end fitting) with a maximum design tension of 7,500 lbs. (33.4 kN).
  - 10.7.2. The maximum diameter of the insulator weather shed (including grading ring, if provided) shall not exceed 14 inches.
- 10.8. 115 & 230kV line post insulators shall have a flat base support and must fit into the Post Insulator Bracket Assembly, as per Figure 1.
- 10.9. **Material**
  - 10.9.1. The complete composite insulator shall consist of a core, housing (includes sheath and shed), and metal end fittings.
  - 10.9.2. The housing material shall be made of 100% silicone rubber prior to the addition of fillers.
  - 10.9.3. The polymer sheath and weather sheds shall be made of a material resistant to ultraviolet (UV) radiation exposure.
  - 10.9.4. Steel parts, except cotter pin, shall have the strength to withstand the load specified with the applicable safety factors.
  - 10.9.5. The coating of steel parts shall be as follows:
    - 10.9.5.1. Galvanizing shall be made after complete fabrication in accordance with ASTM A153. The fabricated product after galvanizing shall be free and clear of acid drops, tear drop membrane, clean, attractive, and unscarred when received. Pieces having galvanizing which does not meet these requirements shall be rejected.

- 10.9.5.2. The continuity of the coating application shall be in accordance with the test method described in ASTM A239 (six successive baths required).
- 10.9.6. The insulator shall be provided with high temperature vulcanized silicone rubber weather sheds, vulcanized or bonded to the fiberglass rod at intervals to provide optimum electrical performance. The strength of the silicone rubber to the rod interface shall be greater than the tearing strength of the silicone rubber.
- 10.9.7. No radial joints shall be made along the length of the sheath regardless of the distance between the end fittings. The sheath of pre-molded sheath with weather shed shall be extended inside the end fittings to protect the fiberglass core from moisture and to eliminate the possibility of discharge at joints.
- 10.9.8. The thickness of the sheath or weather shed covering over the rod shall not be less than  $\frac{1}{8}$ ".
- 10.9.9. Cotter pin shall be made from cold drawn wire of bronze, brass, or stainless steel.
- 10.9.10. The reinforced fiberglass core shall consist of glass fibers in a resin matrix and shall be designed to withstand temperatures above 160° C without loss of its electrical and mechanical properties.

#### 10.10. Tests

- 10.10.1. The composite insulators shall be tested in accordance with ANSI C29. 11, ANSI C2 9.1, CSA 411.1, and IEC 61109 standards.
- 10.10.2. Prototype tests shall be done on composite insulators of new designs in four (4) parts as described on section 7 of ANSI C29 .11. Each part may be performed independently on new test specimens. The test specimens shall pass the tests in each part in sequence. Prototype tests are to be performed for each class of insulator to verify the suitability of the prototype design, materials, and method of manufacture.
- 10.10.3. Certified reports of prototype tests performed on complete insulator of identical similar class by an independent Test Laboratory shall be submitted for review and acceptance by LUMA in line up of the actual prototype tests.
- 10.10.4. Type or Design tests shall be performed on composite insulators of new design, to verify those characteristics of a composite insulator which depend on its size and shape.
- 10.10.5. Certified reports of design or type tests, performed on complete insulator of identical design by an independent Test Laboratory, shall be submitted for review and acceptance by LUMA in lieu of the actual design or type tests.
- 10.10.6. The insulator, including all its hardware assembly, shall be tested in a suitable high voltage laboratory to demonstrate that the Corona Extinction Voltage (CEV) is greater than 1.2 times the maximum system operating voltage. If a corona ring is necessary, its surface shall be representative of actual LUMA field conditions.
- 10.10.7. The Manufacturer shall submit evidence of the multi-stress laboratory test reports as per IEC 61109 for the insulator rating specified in the purchase requisition.

10.10.8. The manufacturer shall submit evidence of dye penetration laboratory test reports as per CSA 411.4.

10.10.9. Quality conformance tests shall be performed at random on insulators selected from the lot to be supplied to LUMA.

10.10.10. Routine tests shall be performed on each insulator.

10.10.11. The Supplier shall provide certified copies of the factory tests results reports.

## 11. Inspection

11.1. The acceptance of any material or equipment shall in no way relieve the vendor from his responsibility to meet all the requirements of this specification, and it shall not prevent subsequent rejection if such material is found to be defective later.

## 12. Properties: Warehouse and Asset Suite Identification Number (Table 1)

Polymer Braced Post Insulator	
Electrical Parameters	System Voltage 115 & 230 kV
Min. Leakage Distance	260.8 In
Min. Dry Arc Distance	80.8 In
Dry Low Freq. Avg. Flashover	845 kV
Wet Low Freq. Avg. Flashover	800 kV
Pos. Critical Imp. F. O.	1250 kV
Neg. Critical Imp. F. O.	1345 kV
Max Working Loads (Includes strength factors from NESC)	
Vertical	11,210 Lbs
Transverse Tension	12,500 Lbs
Compression	12,120 Lbs
Longitudinal	1,550 Lbs
Warehouse Code Number	014-85246
Compatible Manufacturer & Model	Hubbell Power Systems QUADRI SIL BRACED LINE POST ASSY. CAT NO. BLP483F14003

### 13. Drawings

Typical dimensions:

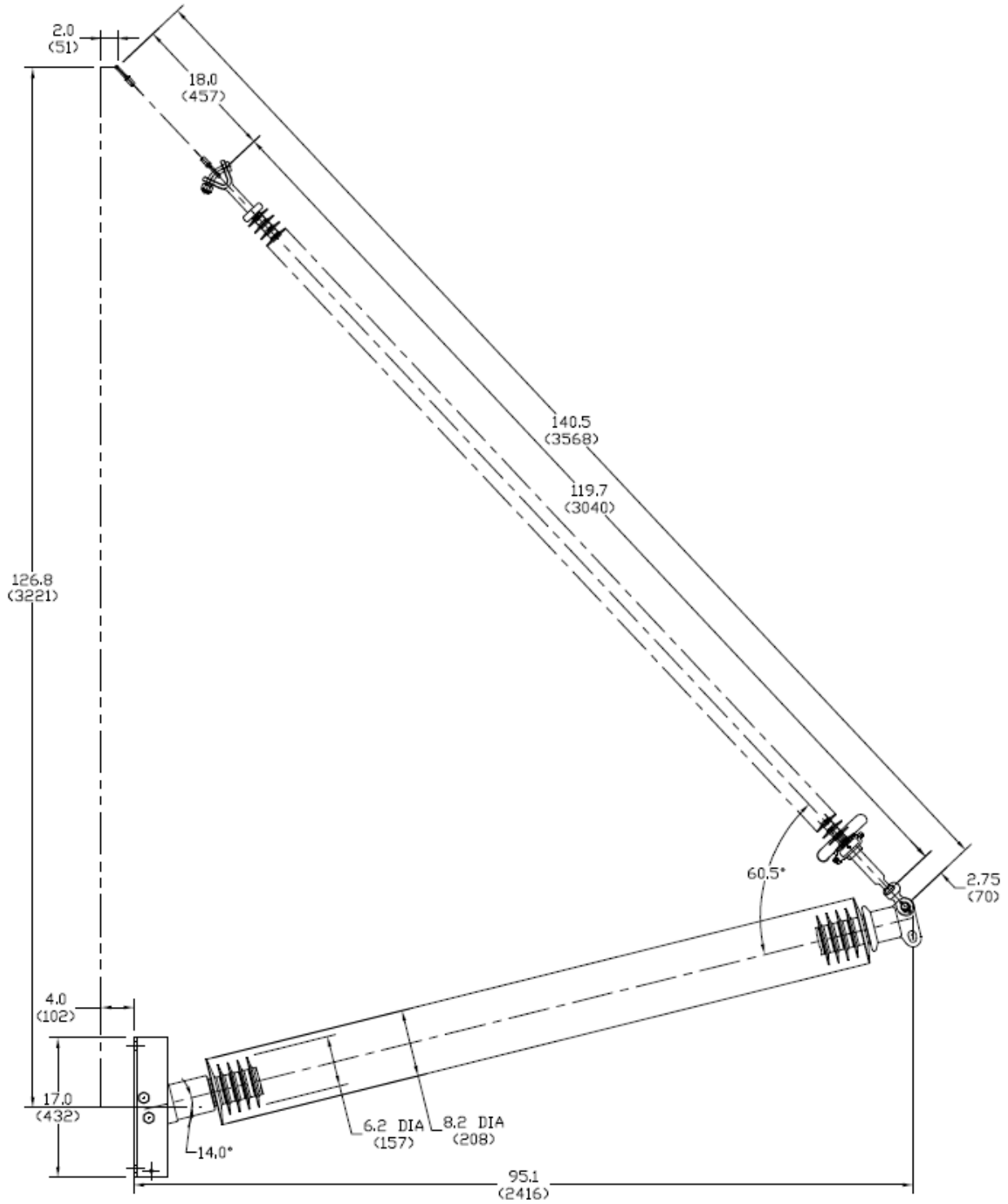

**FIGURE 1**

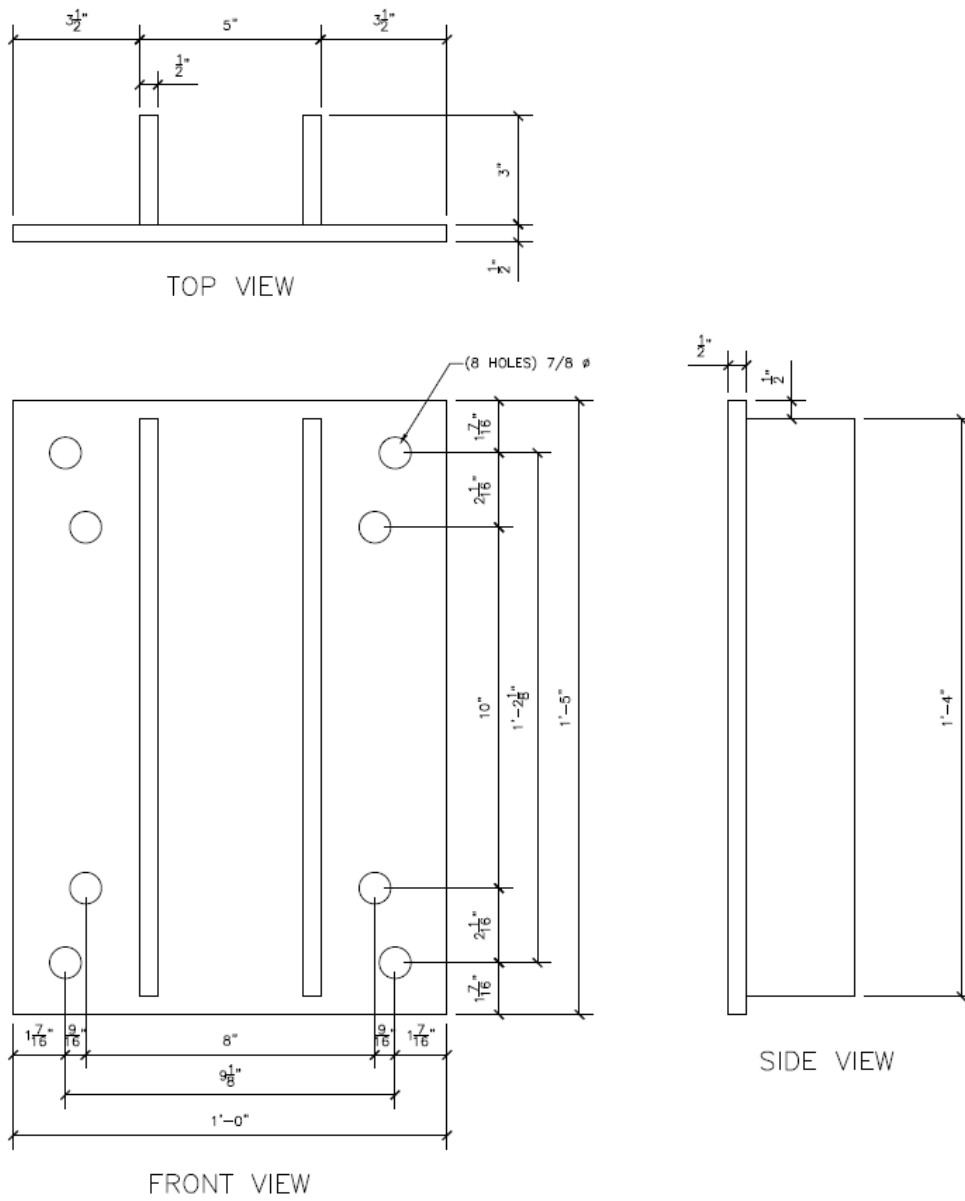

**Post Insulator Bracket Assembly 115 & 230 kV**

— End of Specification —











# 4752.330 Polimer Braced Post Insulator 115 230 kV

Final Audit Report

2023-11-09

Created:	2023-10-31
By:	Koral Caro Rivera (koral.carorivera@lumapr.com)
Status:	Signed
Transaction ID:	CBJCHBCAABAAj5xBCsN0_x3DjNztbRD7Sn15zNZRaTK6

## "4752.330 Polimer Braced Post Insulator 115 230 kV" History

-  Document created by Koral Caro Rivera (koral.carorivera@lumapr.com)  
2023-10-31 - 6:29:30 PM GMT
-  Document e-signed by Koral Caro Rivera (koral.carorivera@lumapr.com)  
Signature Date: 2023-10-31 - 6:51:41 PM GMT - Time Source: server
-  Document emailed to Leonardo Montes Sanchez (leonardo.montessanch@lumapr.com) for signature  
2023-10-31 - 6:51:42 PM GMT
-  Email viewed by Leonardo Montes Sanchez (leonardo.montessanch@lumapr.com)  
2023-10-31 - 6:52:21 PM GMT
-  Document e-signed by Leonardo Montes Sanchez (leonardo.montessanch@lumapr.com)  
E-signature obtained using URL retrieved through the Adobe Acrobat Sign API  
Signature Date: 2023-11-06 - 5:48:27 PM GMT - Time Source: server
-  Document emailed to Juan Carlos Miranda (juanc.miranda@lumapr.com) for signature  
2023-11-06 - 5:48:28 PM GMT
-  Email viewed by Juan Carlos Miranda (juanc.miranda@lumapr.com)  
2023-11-06 - 5:55:08 PM GMT
-  Document e-signed by Juan Carlos Miranda (juanc.miranda@lumapr.com)  
Signature Date: 2023-11-06 - 6:12:49 PM GMT - Time Source: server
-  Document emailed to oscar.venegas@lumapr.com for signature  
2023-11-06 - 6:12:51 PM GMT
-  Email viewed by oscar.venegas@lumapr.com  
2023-11-09 - 6:14:45 PM GMT

 Signer oscar.venegas@lumapr.com entered name at signing as Oscar E Venegas

2023-11-09 - 6:16:06 PM GMT

 Document e-signed by Oscar E Venegas (oscar.venegas@lumapr.com)

Signature Date: 2023-11-09 - 6:16:08 PM GMT - Time Source: server- Signature captured from device with phone number XXXXXXX2079

 Agreement completed.

2023-11-09 - 6:16:08 PM GMT