



Document Title:  
**Yoke Plate Triangular 80K**

Document Type:  
**Specification**

Engineering Type  
**Material Specification**

Document No.:  
**4752.324**

Department:

Version:  
01

Effective Date:  
Dec 19, 2024

**Transmission Engineering**

Shared document with: N/A

**Author**

Guillermo J. Nieves Díaz  
Technical Specialist 1, Transmission Lines Engineering Design & Standards

  
Guillermo Nieves (Dec 6, 2024 16:26 AST)

**Reviewer 1**

Leonardo Montes Sánchez  
Engineer 2, Transmission Lines Engineering Design & Standards

  
Leonardo Montes Sanchez (Dec 9, 2024 16:05 AST)

**Reviewer 2**

Oscar Venegas  
Supervisor, Transmission Lines Engineering Design & Standards

  
Oscar E Venegas (Dec 19, 2024 14:12 AST)

**Approver**

Yamil I. Rivera Hernández  
Section Manager, Transmission Lines Engineering Design

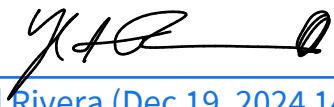
  
Yamil Rivera (Dec 19, 2024 14:22 AST)

**Management Approval (If apply)**

**Approver**

Name  
Position

Signature and Date

**Related/Referenced Documents**

Version	Date	Revision Comments
00	May 30, 2023	First Issue
01	Dec 19, 2024	Changed cover page and document to new format. Modified sections 4 and 7. Added a table of compliance and Proposal Information. Changed Equal or approved equal to Compatible with and was modified.

## **1. General**

### **1.1. Overview**

- 1.1.1. This is a general specification that covers the minimum requirements for a Yoke Plate Triangular to be used in the transmission system in Puerto Rico.
- 1.1.2. Further information will be provided by LUMA Energy at the time of order placement and will provide information on site conditions, quantity, and other requirements.
- 1.1.3. This document includes the general electrical and mechanical characteristics of the material.

## **2. Specific Name**

- 2.1. Yoke Plate Triangular 80k.

## **3. Basic Use**

- 3.1. For attaching high capacity deadend conductor support assembly on overhead transmission lines that require heavy tensions.

## **4. Specific Requirements**

- 4.1. Samples shall be furnished to LUMA.
- 4.2. LUMA requires One (1) unit properly labeled for testing and analysis.
- 4.3. Descriptive and technical literature shall be supplied to LUMA.
- 4.4. They shall be required to show evidence of LUMA's approval of the equipment.

## **5. Acceptance Criteria**

- 5.1. Latest applicable codes, standards, and other regulations: ANSI/ASTM.

## **6. Description**

- 6.1. Configuration (Shape): Delta (Triangular)
- 6.2. Minimum Required Ultimate Strength: 80,000 lbs.
- 6.3. Material: Body – galvanized ductile iron.
- 6.4. Length: 18 inches.
- 6.5. Minimum Width: 5 inches.
- 6.6. Minimum Thickness:  $\frac{3}{4}$  to 1  $\frac{1}{8}$  inches.
- 6.7. Minimum Holes Required: 3
- 6.8. Minimum Hole Size Diameter: 1 to 1  $\frac{1}{4}$  inches.
- 6.9. Shall be hot-dip galvanized in accordance with ANSI/ASTM A153.

6.10. Metric conversion as per latest ASTM.

## **7. Markings and Packaging**

- 7.1. Containers/pallets or package shall be marked outside with LUMA'S purchase order number and code number.
- 7.2. Vendor shall prepare material and equipment for shipment in such manner as to facilitate handling and protection for damage.
- 7.3. All material should be packaged and marked in such a way that the receiving warehouse can readily identify and send in one (1) complete unit to a field location without opening crates or boxes to sort items and / or parts.
- 7.4. Containers or boxes shall be marked with the following information:
  - 7.4.1. Vendor
  - 7.4.2. Order Number
  - 7.4.3. Catalog Number
  - 7.4.4. Code Number
  - 7.4.5. Name and Size
  - 7.4.6. Net weight and gross weight
  - 7.4.7. Manufacturer Name and lot number
  - 7.4.8. Material Name
  - 7.4.9. Number per package: As approved by LUMA

## **8. Compatible with**

- 8.1. Hubbel Power System – Catalog Number YPD8018475 (See drawing A)
- 8.2. MacLean Power Systems - Catalog Number Y2DT080D1800 (See drawing B)
- 8.3. These models are an example of the equipment/material described in this document and do not represent a preference. LUMA will evaluate equally any model not listed here during any acquisition event.

## **9. Proposal Information**

- 9.1. Submitted proposals must include:
  - a. Technical Information
  - b. Table of Compliance completed by the bidder with reference

**10. Inspection**

**10.1.** The acceptance of any material or equipment shall in no way relieve the vendor from his responsibility to meet all the requirements of this specification, and it shall not prevent subsequent rejection if such material is found to be defective later

**11. Drawings**

**Figure 1: Drawing A**

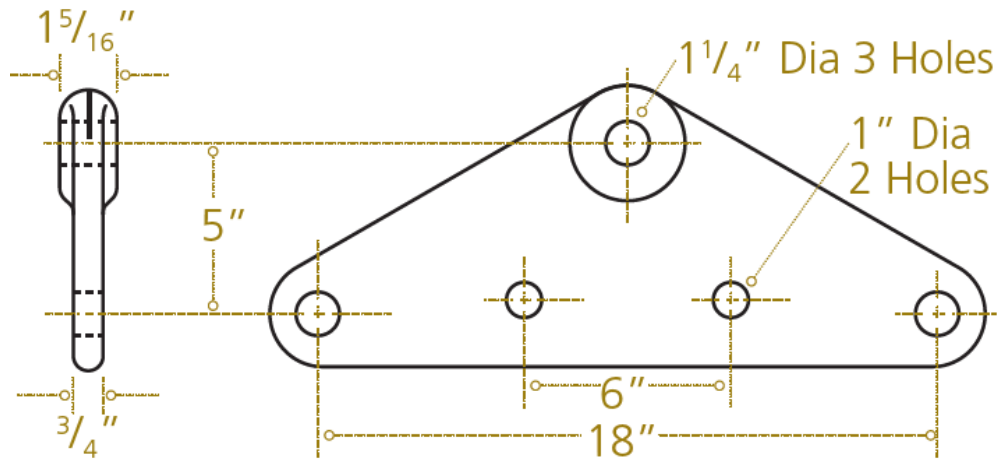

**Figure 2: Drawing B**

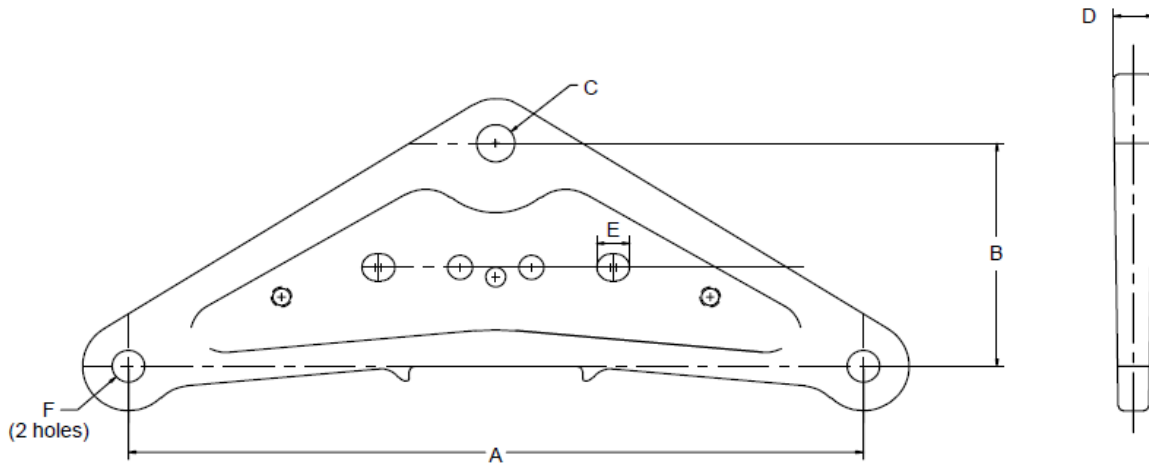

**Table 1: Dimensions B**

A	B	C	D	E	F
18"	6"	1.19"	1.38"	.94"	1.06"

Warehouse ID	002-84818
--------------	-----------

— End of Specification —

## Appendix

Appendix 1. Table of Compliance

Line	Criteria	Description	Pass/Fail (P / F)	Comments
1	Specification	The Proponent complies with the corresponding specification document (4752.324)		
2	Industry Standards	The Proponent complies with the industry standards established in the specification document (ANSI, ASTM)		
3	Material	Yoke Plate Triangular 80k. <ul style="list-style-type: none"> <li>• Minimum Required Ultimate Strength: 80,000 lbs.</li> <li>• Material: Body – galvanized ductile iron.</li> <li>• Shall be hot-dip galvanized in accordance with ANSI/ASTM A153.</li> </ul>		
4	Dimensions	<ul style="list-style-type: none"> <li>• Complies with Table 1</li> <li>• Length: 18 inches.</li> <li>• Minimum Width: 5 inches.</li> <li>• Minimum Thickness: ¾ to 1 1/8 inches.</li> <li>• Minimum Holes Required: 3</li> <li>• Minimum Hole Size Diameter: 1 to 1 1/4 inches.</li> </ul>		
5	Requirements	<ul style="list-style-type: none"> <li>• Samples shall be furnished to LUMA.</li> <li>• LUMA requires One (1) unit properly labeled for testing and analysis.</li> <li>• Descriptive and technical literature shall be supplied to LUMA.</li> <li>• They shall be required to show evidence of LUMA’s approval of the equipment.</li> </ul>		











# 4752.324 Yoke Plate Triangular 80,000 lbs

Final Audit Report

2024-12-19

Created:	2024-12-06
By:	Guillermo Nieves (guillermoj.nievesdia@lumapr.com)
Status:	Signed
Transaction ID:	CBJCHBCAABAAZQ0GPITWmWJurwLbj8P6RELe3lkrvIMt

## "4752.324 Yoke Plate Triangular 80,000 lbs" History

-  Document created by Guillermo Nieves (guillermoj.nievesdia@lumapr.com)  
2024-12-06 - 8:25:17 PM GMT
-  Document e-signed by Guillermo Nieves (guillermoj.nievesdia@lumapr.com)  
Signature Date: 2024-12-06 - 8:26:05 PM GMT - Time Source: server
-  Document emailed to Leonardo Montes Sanchez (leonardo.montessanch@lumapr.com) for signature  
2024-12-06 - 8:26:06 PM GMT
-  Document e-signed by Leonardo Montes Sanchez (leonardo.montessanch@lumapr.com)  
Signature Date: 2024-12-09 - 8:05:37 PM GMT - Time Source: server- Signature captured from device with phone number XXXXXXXX5488
-  Document emailed to Oscar Venegas (oscar.venegas@lumapr.com) for signature  
2024-12-09 - 8:05:38 PM GMT
-  Signer Oscar Venegas (oscar.venegas@lumapr.com) entered name at signing as Oscar E Venegas  
2024-12-19 - 6:12:29 PM GMT
-  Document e-signed by Oscar E Venegas (oscar.venegas@lumapr.com)  
Signature Date: 2024-12-19 - 6:12:31 PM GMT - Time Source: server- Signature captured from device with phone number XXXXXXXX2079
-  Document emailed to Yamil Rivera (yamil.rivera@lumapr.com) for signature  
2024-12-19 - 6:12:33 PM GMT
-  Email viewed by Yamil Rivera (yamil.rivera@lumapr.com)  
2024-12-19 - 6:22:08 PM GMT
-  Document e-signed by Yamil Rivera (yamil.rivera@lumapr.com)  
Signature Date: 2024-12-19 - 6:22:25 PM GMT - Time Source: server
-  Agreement completed.  
2024-12-19 - 6:22:25 PM GMT