



Document Title:  
**Ball Y Clevis 50,000 lbs**

Document Type:  
**Specification**

Engineering Type  
**Material Specification**

Document No.:  
**4752.322**

Department:

Version:  
01

Effective Date:  
Dec 19, 2024

**Transmission  
Engineering**

Shared document with: N/A

**Author**

Guillermo J. Nieves Díaz  
Technical Specialist 1, Transmission Lines Engineering  
Design & Standards

  
Guillermo Nieves (Dec 6, 2024 16:19 AST)

**Reviewer 1**

Leonardo Montes Sánchez  
Engineer 2, Transmission Lines Engineering Design &  
Standards

  
Leonardo Montes Sanchez (Dec 9, 2024 16:04 AST)

**Reviewer 2**

Oscar Venegas  
Supervisor, Transmission Lines Engineering Design &  
Standards

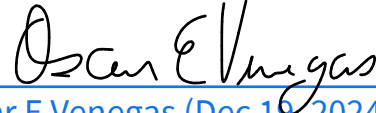
  
Oscar E Venegas (Dec 19, 2024 14:05 AST)

**Approver**

Yamil I. Rivera Hernández  
Section Manager, Transmission Lines Engineering  
Design

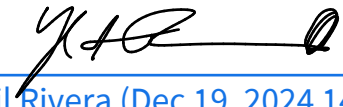
  
Yamil Rivera (Dec 19, 2024 14:20 AST)

**Management Approval (If apply)**

**Approver**

Name  
Position

Signature and Date

**Related/Referenced Documents**

| Version | Date         | Revision Comments   |
|---------|--------------|---|
| 00      | May 30, 2023 | First Issue   |
| 01      | Dec 19, 2024 | Changed cover page and document to new format. Modified sections 4 and 7. Added a table of compliance. Equal or approved Equal changed to Compatible with and was modified. |
|         |              |   |

## **1. General**

### **1.1. Overview**

- 1.1.1. This is a general specification that covers the minimum requirements for a Ball Y Clevis 50,000 lbs to be used in the transmission system in Puerto Rico.
- 1.1.2. Further information will be provided by LUMA Energy at the time of order placement and will provide information on site conditions, quantity, and other requirements.
- 1.1.3. This document includes the general electrical and mechanical characteristics of the material.

## **2. Specific Name**

- 2.1. Ball Y-Clevis Connector 50,000 lbs.

## **3. Basic Use**

- 3.1. For attaching high capacity deadend conductor support assembly on overhead transmission lines that require heavy tensions.

## **4. Specific Requirements**

- 4.1. Samples shall be furnished to LUMA.
- 4.2. LUMA requires One (1) unit properly labeled for testing and analysis.
- 4.3. Descriptive and technical literature shall be supplied to LUMA.
- 4.4. They shall be required to show evidence of LUMA's approval of the equipment.

## **5. Acceptance Criteria**

- 5.1. Latest applicable codes, standards, and other regulations: ANSI/ASTM.

## **6. Description**

- 6.1. Ball Y Clevis connector shall be made with an ultimate strength of 50,000LBF minimum, as per ANSI Class 52-11.
- 6.2. Ball Y Clevis connector shall fit ball and socket insulators ANSI classes 52-8 and 52-11 per ANSI Spec. C-29.2-71.
- 6.3. Body shall be galvanized ductile iron.
- 6.4. Clevis pin shall be galvanized steel.
- 6.5. Cotter Pin shall be stainless steel.
- 6.6. Shall be hot-dip galvanized in accordance with ANSI/ASTM A153.
- 6.7. Metric conversion as per latest ASTM.

**7. Markings and Packaging**

- 7.1. Containers/pallets or package shall be marked outside with LUMA'S purchase order number and code number.
- 7.2. Vendor shall prepare material and equipment for shipment in such manner as to facilitate handling and protection for damage.
- 7.3. All material should be packaged and marked in such a way that the receiving warehouse can readily identify and send in one (1) complete unit to a field location without opening crates or boxes to sort items and / or parts.
- 7.4. Twenty five (25) units per box, or as requested by LUMA.

**8. Compatible with:**

- 8.1. Hubbell Power System catalog No. YBC-50
- 8.2. MacLean Power Systems YCB-78.
- 8.3. These models are an example of the equipment/material described in this document and do not represent a preference. LUMA will evaluate equally any model not listed here during any acquisition event.

**9. Proposal Information**

- 9.1. Submitted proposals must include:
  - a. Technical Information
  - b. Table of Compliance completed by the bidder with reference

**10. Inspection**

- 10.1. The acceptance of any material or equipment shall in no way relieve the vendor from his responsibility to meet all the requirements of this specification, and it shall not prevent subsequent rejection if such material is found to be defective later

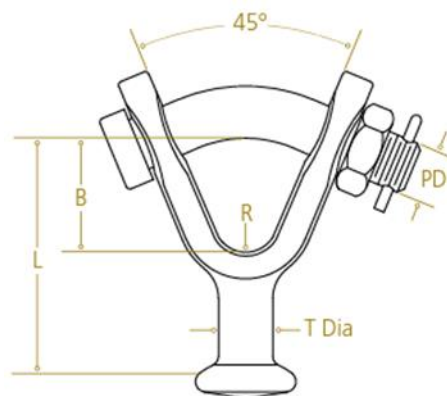
**11. Drawings**

**Table 1:** Dimensions

| L MIN. | B MIN.                            | T Dia                           | R MIN. | PD                            |
|--------|-----------------------------------|---------------------------------|--------|-------------------------------|
| 3.81"  | 1 <sup>13</sup> / <sub>16</sub> " | <sup>57</sup> / <sub>64</sub> " | 0.531" | <sup>7</sup> / <sub>8</sub> " |

|              |           |
|--------------|-----------|
| Warehouse ID | 002-84816 |
|--------------|-----------|

— End of Specification —

## Appendix

Appendix 1. Table of Compliance

| Line | Criteria           | Description   | Pass/Fail<br>(P / F) | Comments |
|------|--------------------|---|----------------------|----------|
| 1    | Specification      | The Proponent complies with the corresponding specification document (4752.322)   |                      |          |
| 2    | Industry Standards | The Proponent complies with the industry standards established in the specification document (ANSI, ASTM)   |                      |          |
| 3    | Material           | <p>Ball Y Clevis Connector 50,000 lbs.</p> <ul style="list-style-type: none"> <li>• Shall be made from drop-forged steel with an ultimate strength of 50,000LBF minimum, as per ANSI Class 52-11.</li> <li>• Shall fit ball and socket insulators ANSI classes 52-8 and 52-11 per ANSI Spec. C-29.2-71.</li> <li>• Body shall be galvanized ductile iron.</li> <li>• Hardware shall be galvanized steel.</li> <li>• Cotter Pin shall be stainless steel.</li> <li>• Shall be hot-dip galvanized in accordance with ANSI/ASTM A153.</li> </ul> |                      |          |
| 4    | Dimensions         | Complies with Table 1   |                      |          |
| 5    | Requirements       | <ul style="list-style-type: none"> <li>• Samples shall be furnished to LUMA.</li> <li>• Descriptive and technical literature shall be supplied to LUMA.</li> <li>• Required to be certified by external laboratories.</li> </ul>  |                      |          |











# 4752.322 Ball Y-Clevis Connector 50,000 lbs

Final Audit Report

2024-12-19

|                 |  |
|-----------------|--|
| Created:        | 2024-12-06   |
| By:             | Guillermo Nieves (guillermoj.nievesdia@lumapr.com) |
| Status:         | Signed   |
| Transaction ID: | CBJCHBCAABAAPRSqz32mqXkWKD4TGKjwJCZCNAnmNLyN       |

## "4752.322 Ball Y-Clevis Connector 50,000 lbs" History

-  Document created by Guillermo Nieves (guillermoj.nievesdia@lumapr.com)  
2024-12-06 - 8:19:06 PM GMT
-  Document e-signed by Guillermo Nieves (guillermoj.nievesdia@lumapr.com)  
Signature Date: 2024-12-06 - 8:19:48 PM GMT - Time Source: server
-  Document emailed to Leonardo Montes Sanchez (leonardo.montessanch@lumapr.com) for signature  
2024-12-06 - 8:19:49 PM GMT
-  Document e-signed by Leonardo Montes Sanchez (leonardo.montessanch@lumapr.com)  
Signature Date: 2024-12-09 - 8:04:18 PM GMT - Time Source: server- Signature captured from device with phone number XXXXXXX5488
-  Document emailed to Oscar Venegas (oscar.venegas@lumapr.com) for signature  
2024-12-09 - 8:04:19 PM GMT
-  Signer Oscar Venegas (oscar.venegas@lumapr.com) entered name at signing as Oscar E Venegas  
2024-12-19 - 6:05:34 PM GMT
-  Document e-signed by Oscar E Venegas (oscar.venegas@lumapr.com)  
Signature Date: 2024-12-19 - 6:05:36 PM GMT - Time Source: server- Signature captured from device with phone number XXXXXXX2079
-  Document emailed to Yamil Rivera (yamil.rivera@lumapr.com) for signature  
2024-12-19 - 6:05:38 PM GMT
-  Email viewed by Yamil Rivera (yamil.rivera@lumapr.com)  
2024-12-19 - 6:20:00 PM GMT
-  Document e-signed by Yamil Rivera (yamil.rivera@lumapr.com)  
Signature Date: 2024-12-19 - 6:20:21 PM GMT - Time Source: server
-  Agreement completed.  
2024-12-19 - 6:20:21 PM GMT