



Document Title:
Steel Crossarm, W10x22x36-4

Document Type:
Specification

Engineering Type
Material Specification

Document No.:
4752.317

Department:

Version:
01

Effective Date:
Dec 19, 2024

**Transmission
Engineering**

Shared document with: N/A

Author

Guillermo J. Nieves Díaz
Technical Specialist 1, Transmission Lines Engineering
Design & Standards



Guillermo Nieves (Dec 6, 2024 16:14 AST)

Reviewer 1

Leonardo Montes Sánchez
Engineer 2, Transmission Lines Engineering Design &
Standards



Leonardo Montes Sanchez (Dec 9, 2024 15:49 AST)

Reviewer 2

Oscar Venegas
Supervisor, Transmission Lines Engineering Design &
Standards



Oscar E Venegas (Dec 19, 2024 13:51 AST)

Approver

Yamil I. Rivera Hernández
Section Manager, Transmission Lines Engineering
Design

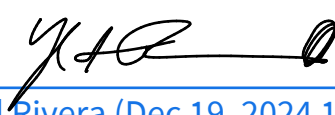

Yamil Rivera (Dec 19, 2024 13:53 AST)

Management Approval (If apply)

Approver

Name
Position

Signature and Date

Related/Referenced Documents

Version	Date	Revision
00	Mar 14, 2023	First Issue
01	Dec 19, 2024	Changed cover page and document to new format. Modified sections 4 and 7. Added a table of compliance. Equal or approved to changed to Compatible with and modified.

1. General

1.1. Overview

- 1.2. This is a general specification that covers the minimum requirements for a galvanized steel crossarm shelf gain to be used in the transmission system in Puerto Rico.
 - 1.2.1. Further information will be provided by LUMA Energy at the time of order placement and will provide information on site conditions, quantity, and other requirements.
 - 1.2.2. This document includes the general mechanical and fabrication characteristics of the material.

2. Specific Name

- 2.1. Steel Crossarm, W10x22x36-4

3. Basic Use

- 3.1. For tangent H-frame structure conductor support.

4. Specific Requirements

- 4.1. Samples shall be furnished to LUMA.
- 4.2. LUMA requires One (1) unit properly labeled for testing and analysis.
- 4.3. Descriptive and technical literature shall be supplied to LUMA.
- 4.4. They shall be required to show evidence of LUMA's approval of the equipment.

5. Acceptance Criteria

- 5.1. Latest applicable codes, standards and other regulations: ANSI/ASTM.
- 5.2. Steel material per: ASTM A-572, GR-50 or A-242, GR-50.
- 5.3. Steel shall be galvanized per ASTM A123
- 5.4. The crossarms should be constructed from a single steel piece, without welding to achieve the required length.
- 5.5. All holes, slots, or other fabrication adjustments shall be made prior to galvanizing. No "cold galv" or paint shall be accepted.
- 5.6. Galvanized coating shall be in good condition, and show no signs of flaking, delamination from the steel surface, or scratches/damage from handling or transport.

6. Description

- 6.1. Shape: W10x22
- 6.2. Length: 36' – 4"

6.2.1. Length to be made of a single steel W10x22x36'-4" piece. No welds of multiple pieces to achieve the required length will be accepted.

7. Markings and Packaging

7.1. Containers/pallets or package shall be marked outside with LUMA'S purchase order number and code number.

7.2. Vendor shall prepare material and equipment for shipment in such manner as to facilitate handling and protection for damage.

7.3. All material should be packaged and marked in such a way that the receiving warehouse can readily identify and send in one (1) complete unit to a field location without opening crates or boxes to sort items and / or parts.

7.4. Number per package: As per LUMA's needs.

8. Compatible with:

8.1. Fabrication detail per drawing.

8.2. These models are an example of the equipment/material described in this document and do not represent a preference. LUMA will evaluate equally any model not listed here during any acquisition event.

9. Proposal Information

9.1. Submitted proposals must include:

- a. Technical Information
- b. Table of Compliance completed by the bidder with reference

10. Inspection

10.1. The acceptance of any material or equipment shall in no way relieve the vendor from his responsibility to meet all the requirements of this specification, and it shall not prevent subsequent rejection if such material is found to be defective later

11. Drawings

ITEM NO. XXXX GALVANIZED			
BILL OF MATERIAL			
ITEM NO.	QTY.	DESCRIPTION	WT. LBS.
1	1	W10_x_22" _x_36'-4" _ASTM_A242,_GRADE_50	-----
TOTAL APPROX. WT. (AFTER GALVANIZING)			-----

NOTE: A242 VERSION SHALL BE GALVANIZED PER ASTM A123.

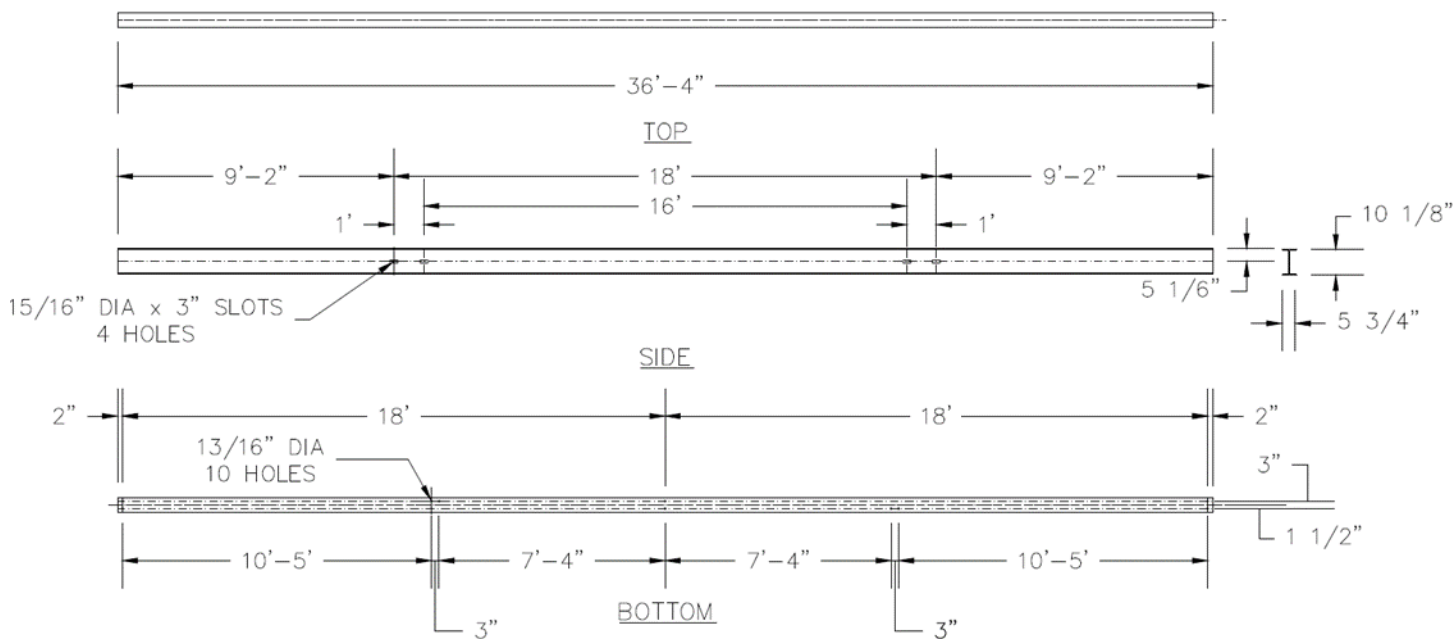

Warehouse ID	008-84426
--------------	-----------

— End of Specification —

Appendix

Appendix 1. Table of Compliance

Line	Criteria	Description	Pass/Fail (P / F)	Comments
1	Specification	The Proponent complies with the corresponding specification document (4752.317)		
2	Industry Standards	The Proponent complies with the industry standards established in the specification document (ANSI, ASTM).		
3	Material	<p>Steel Crossarm, W10x22x36-4 Minimum ultimate strength of 36,000 lbs.</p> <ul style="list-style-type: none"> • Steel material per: ASTM A-572, GR-50 or A-242, GR-50. • Steel shall be galvanized per ASTM A123 • The crossarms should be constructed from a single steel piece, without welding to achieve the required length. • All holes, slots, or other fabrication adjustments shall be made prior to galvanizing. No “cold galv” or paint shall be accepted. • Galvanized coating shall be in good condition, and show no signs of flaking, delamination from the steel surface, or scratches/damage from handling or transport. 		
4	Requirements	<ul style="list-style-type: none"> • Samples shall be furnished to LUMA. • LUMA requires One (1) unit properly labeled for testing and analysis. • Descriptive and technical literature shall be supplied to LUMA. Vendors that have supplied this material to PREPA in previous orders, will not have to furnish samples at bid opening. • They shall be required to show evidence of LUMA’s approval of the equipment. 		











4752.317 Steel Crossarm - W10x22x36-4

Final Audit Report

2024-12-19

Created:	2024-12-06
By:	Guillermo Nieves (guillermoj.nievesdia@lumapr.com)
Status:	Signed
Transaction ID:	CBJCHBCAABAAOse1bk2ein4ZKA2WSIVWPR0_NXv2zmU0

"4752.317 Steel Crossarm - W10x22x36-4" History

-  Document created by Guillermo Nieves (guillermoj.nievesdia@lumapr.com)
2024-12-06 - 8:13:36 PM GMT
-  Document e-signed by Guillermo Nieves (guillermoj.nievesdia@lumapr.com)
Signature Date: 2024-12-06 - 8:14:18 PM GMT - Time Source: server
-  Document emailed to Leonardo Montes Sanchez (leonardo.montessanch@lumapr.com) for signature
2024-12-06 - 8:14:20 PM GMT
-  Document e-signed by Leonardo Montes Sanchez (leonardo.montessanch@lumapr.com)
Signature Date: 2024-12-09 - 7:49:44 PM GMT - Time Source: server- Signature captured from device with phone number XXXXXXXX5488
-  Document emailed to Oscar Venegas (oscar.venegas@lumapr.com) for signature
2024-12-09 - 7:49:45 PM GMT
-  Signer Oscar Venegas (oscar.venegas@lumapr.com) entered name at signing as Oscar E Venegas
2024-12-19 - 5:51:09 PM GMT
-  Document e-signed by Oscar E Venegas (oscar.venegas@lumapr.com)
Signature Date: 2024-12-19 - 5:51:11 PM GMT - Time Source: server- Signature captured from device with phone number XXXXXXXX2079
-  Document emailed to Yamil Rivera (yamil.rivera@lumapr.com) for signature
2024-12-19 - 5:51:13 PM GMT
-  Email viewed by Yamil Rivera (yamil.rivera@lumapr.com)
2024-12-19 - 5:53:28 PM GMT
-  Document e-signed by Yamil Rivera (yamil.rivera@lumapr.com)
Signature Date: 2024-12-19 - 5:53:56 PM GMT - Time Source: server
-  Agreement completed.
2024-12-19 - 5:53:56 PM GMT