



38kV Pole Steel Equipment Arm

Equipment Specification

Document No.: 4752.295

Item No.: 026-84099

Originating Dept: Transmission Eng.



Document Title:

38kV Pole Steel Equipment Arm

Document Type:

Equipment Specification

Document No.:

4752.295

Department Users:

Transmission Engineering

Version:

00

Effective Date:

Jan 27, 2023

Author

Leonardo Montes
Engineer in Training, T&S Standards and Materials

Signature and Date

[Leonardo Montes Sanchez \(Jan 24, 2023 10:03 AST\)](#)

Reviewer 1

Rene Maldonado
Supervisor, Transmission Line Engineering Standards

Signature and Date

[Rene Maldonado \(Jan 24, 2023 10:23 AST\)](#)

Reviewer 2

Oscar Venegas
Lead Engineer, Transmission Line

Signature and Date

[Oscar E Venegas \(Jan 26, 2023 09:14 AST\)](#)

Approver

Walter Carrasquillo, PE (Lic. # 15411)
Manager, T&S Standards and Materials

Signature and Date

[Walter Carrasquillo \(Jan 27, 2023 07:34 AST\)](#)

Management Approval

Heriberto González
Section Manager, T&S Standards and Materials

Signature and Date

[Heriberto Gonzalez \(Jan 27, 2023 10:16 AST\)](#)

Version History

| Version | Date | Revision Comments |
|---------|--------------|-------------------|
| 00 | Jan 27, 2023 | First Issue |
| | | |
| | | |
| | | |



1. General

- 1.1. This is a general specification that covers the minimum requirements for 38kV Pole Steel Equipment Arm to be used in the transmission overhead system in Puerto Rico.
- 1.2. Further information will be provided by LUMA Energy at the time of order placement and will provide information on site conditions, quantity, and other requirements.
- 1.3. This document includes the general electrical and mechanical characteristics of the material.

2. Specific Name

- 2.1. 38kV Pole Steel Equipment Arm

3. Basic Use

- 3.1. For installation of 38kV lightning arrester and/or 38kV station post insulator on transmission structure to assemble 38kV Transmission Line Riser.

4. Special Requirements

- 4.1. Samples shall be furnished if requested by LUMA.
- 4.2. LUMA may require one (1) unit properly labeled for testing and analysis.
- 4.3. Descriptive and technical literature shall be supplied if requested by LUMA.

5. Marking and Packaging

- 5.1. All material and equipment shall be packaged and marked in such a way as to facilitate handling and protection from damage and that the receiving warehouse can readily identify it and send it, in one complete unit, to a field location without opening crates or boxes to sort items and/or parts.

6. Equal or approved equal to:

- 6.1. As approved by LUMA

7. Number per package:

- 7.1. As approved and/or requested by LUMA

8. Acceptance Criteria

- 8.1. Test required: certified by external laboratories.
- 8.2. Shall be designed, rated, and manufactured, and tested in accordance with the latest applicable IEEE, NEMA, ANSI, ASTM, and NEC Standards. If the vendor does not demonstrate its compliance with the applicable standards, these specification requirements and supply the requested documents, the bid may be rejected.
- 8.3. Equipment Arm must be Steel ASTM A36 and hot dip Galvanized as per ANSI/ASTM 153 after all welding, bending, drilling or punching is performed.



- 8.4. Equipment Arm shall be rated to an ultimate vertical load of 1,000 Lbs.
- 8.5. All sharp edges shall be avoided in order to have smooth trims and surfaces all around the equipment arm.

9. Description

- 9.1. Equipment Arm must be Steel ASTM A36, and hot dip galvanized as per ANSI/ASTM 153. Must have a length of 4'-0". Metric conversions as per the latest applicable ASTM Standard.

10. Inspection

- 10.1. The acceptance of any material or equipment shall in no way relieve the vendor from his responsibility to meet all the requirements of this specification, and it shall not prevent subsequent rejection if such material is found to be defective later.

11. Drawing

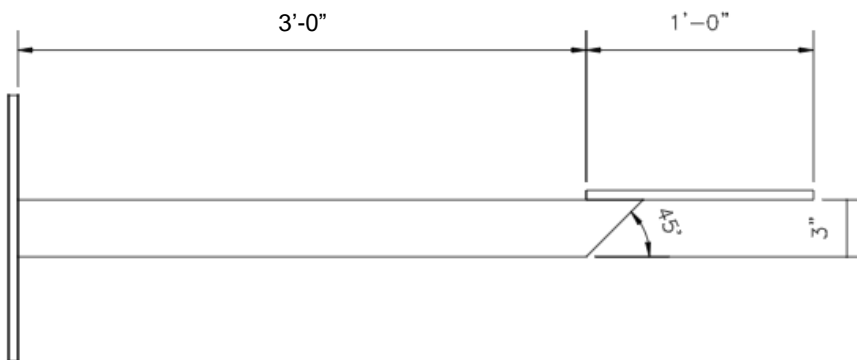

SIDE VIEW

N.T.S.

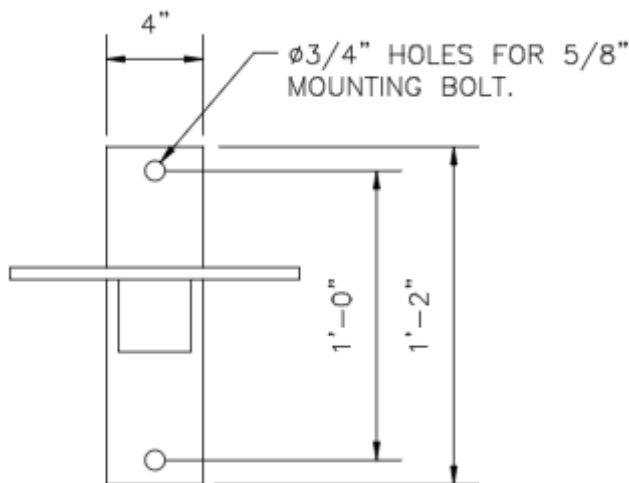

FRONT VIEW

N.T.S.



38kV Pole Steel Equipment Arm

Equipment Specification

Document No.: 4752.295

Item No.: 026-84099

Originating Dept: Transmission Eng.

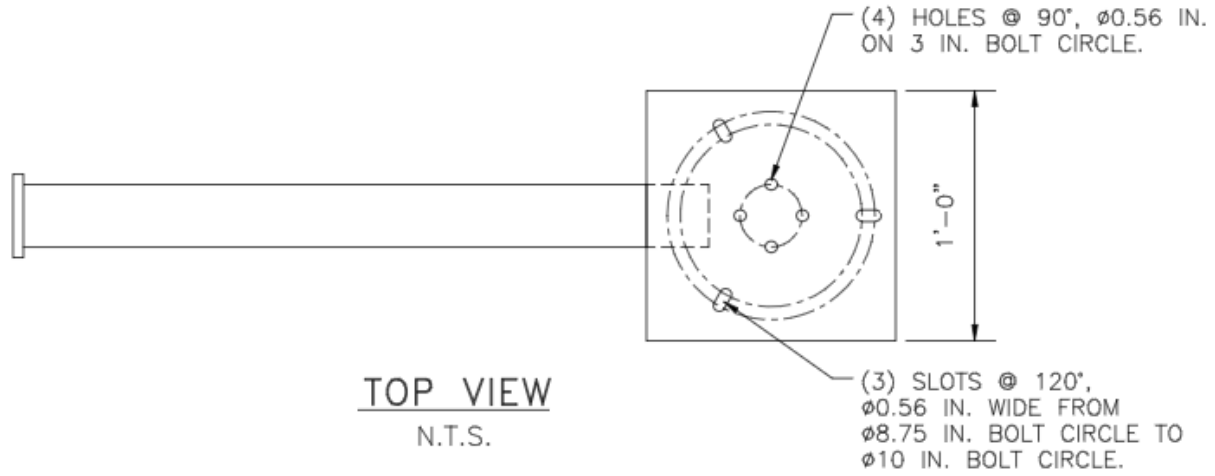

— End of Specification —











4752.295 - 38kV Pole steel Equipment Arm

Final Audit Report

2023-01-27

| | |
|-----------------|-----------------------------------------------------------|
| Created: | 2023-01-24 |
| By: | Leonardo Montes Sanchez (leonardo.montessanch@lumapr.com) |
| Status: | Signed |
| Transaction ID: | CBJCHBCAABAAxNsIPf0VELRiQ53TITwYIzI4FdpBOzFK |

"4752.295 - 38kV Pole steel Equipment Arm" History

-  Document created by Leonardo Montes Sanchez (leonardo.montessanch@lumapr.com)
2023-01-24 - 2:01:29 PM GMT
-  Document e-signed by Leonardo Montes Sanchez (leonardo.montessanch@lumapr.com)
Signature Date: 2023-01-24 - 2:03:43 PM GMT - Time Source: server
-  Document emailed to Rene Maldonado (rene.maldonado@lumapr.com) for signature
2023-01-24 - 2:03:44 PM GMT
-  Email viewed by Rene Maldonado (rene.maldonado@lumapr.com)
2023-01-24 - 2:23:44 PM GMT
-  Document e-signed by Rene Maldonado (rene.maldonado@lumapr.com)
Signature Date: 2023-01-24 - 2:23:56 PM GMT - Time Source: server
-  Document emailed to oscar.venegas@lumapr.com for signature
2023-01-24 - 2:23:57 PM GMT
-  Email viewed by oscar.venegas@lumapr.com
2023-01-24 - 2:59:26 PM GMT
-  Email viewed by oscar.venegas@lumapr.com
2023-01-26 - 1:03:48 PM GMT
-  Signer oscar.venegas@lumapr.com entered name at signing as Oscar E Venegas
2023-01-26 - 1:14:32 PM GMT
-  Document e-signed by Oscar E Venegas (oscar.venegas@lumapr.com)
Signature Date: 2023-01-26 - 1:14:34 PM GMT - Time Source: server- Signature captured from device with phone number XXXXXXX2079
-  Document emailed to Walter Carrasquillo (walter.carrasquillo@lumapr.com) for signature
2023-01-26 - 1:14:35 PM GMT

 Email viewed by Walter Carrasquillo (walter.carrasquillo@lumapr.com)

2023-01-27 - 11:32:43 AM GMT

 Document e-signed by Walter Carrasquillo (walter.carrasquillo@lumapr.com)

Signature Date: 2023-01-27 - 11:34:13 AM GMT - Time Source: server

 Document emailed to Heriberto Gonzalez (heriberto.gonzalez@lumapr.com) for signature

2023-01-27 - 11:34:14 AM GMT

 Email viewed by Heriberto Gonzalez (heriberto.gonzalez@lumapr.com)

2023-01-27 - 2:16:28 PM GMT

 Document e-signed by Heriberto Gonzalez (heriberto.gonzalez@lumapr.com)

Signature Date: 2023-01-27 - 2:16:40 PM GMT - Time Source: server

 Agreement completed.

2023-01-27 - 2:16:40 PM GMT