



	Document Title: Socket Y Clevis 30,000 lbs		
	Document Type: Equipment Specification	Document No.: 4752.278	
Department: Transmission Engineering	Version: 01	Issue Date: 5/27/2022	Effective Date: 5/27/2022

<p>Author Emmanuel E Rivera Cruz Designer, Transmission & Substation Engineering</p> <p>Reviewer 1 Rene Maldonado Supervisor, Line Engineering Standards</p> <p>Reviewer 2 Oscar Venegas Lead Engineer, Trans</p> <p>Approver Walter Carrasquillo Alberty Manager, T&S Standards and Materials</p>	Signature and Date Emmanuel E Rivera Cruz (Jun 2, 2022 16:40 EDT)
	Signature and Date Rene Maldonado (Jun 3, 2022 08:26 EDT)
	Signature and Date Oscar E Venegas (Aug 10, 2022 11:47 EDT)
	Signature and Date Walter Carrasquillo (Aug 10, 2022 13:54 EDT)

Management Approval	
<p>Heriberto González Section Manager, Standards</p> <p>Darrel Wilvers Director, Asset Management</p>	Signature and Date Heriberto Gonzalez (Aug 18, 2022 09:28 EDT)
	Signature and Date N/A

Version History					
Version	Date	Revision Comments	Author	Reviewers	Approver
00	Dec 28, 2021		Rene Maldonado	Heriberto Gonzalez	Walter Carrasquillo
01	May 27, 2022	General revision for final approval	Emmanuel E. Rivera	Rene Maldonado Oscar Venegas	Walter Carrasquillo



1. General

- 1.1. This is a general specification that covers the minimum requirements for a Socket Y Clevis 30,000 lbs to be used in the transmission system in Puerto Rico.
- 1.2. Further information will be provided by LUMA Energy at the time of order placement and will provide information on site conditions, quantity, and other requirements.
- 1.3. This document includes the general electrical and mechanical characteristics of the material.

2. Specific Name

- 2.1. Socket Y Clevis 30,000 lbs.

3. Basic Use

- 3.1. For attach the tangent and deadend conductor support assembly in aluminum transmission towers.

4. Special Requirements

- 4.1. Samples shall be furnished if requested by LUMA.
- 4.2. LUMA may require one (1) unit properly labeled for testing and analysis.
- 4.3. Descriptive and technical literature shall be supplied if requested by LUMA.

5. Marking and Packaging

- 5.1. All material and equipment shall be packaged and marked in such a way as to facilitate handling and protection from damage and that the receiving warehouse can readily identify it and send it, in one complete unit, to a field location without opening crates or boxes to sort items and/or parts.

6. Equal or approved equal to:

- 6.1. Hubble catalog No. SYC30

7. Number per package:

- 7.1. Pallet quantity: 576.

8. Acceptance Criteria

- 8.1. Latest applicable codes, standards, and other regulations: ANSI/ASTM.

9. Description

- 9.1. Socket Y Clevis used to attach the tangent and deadend conductor support assembly in aluminum transmission towers.
- 9.2. Socket Y Clevis shall be made with an ultimate strength of 30,000LBF minimum.
- 9.3. Body shall be galvanized ductile iron
- 9.4. Hardware-Galvanized steel,
- 9.5. Cotter Pin-stainless steel.
- 9.6. Shall be hot-dip galvanized in accordance with ANSI/ASTM A153.
- 9.7. Metric conversion as per latest ASTM.

10. Inspection

- 10.1. The acceptance of any material or equipment shall in no way relieve the vendor from his responsibility to meet all the requirements of this specification, and it shall not prevent subsequent rejection if such material is found to be defective later.

11. Drawing

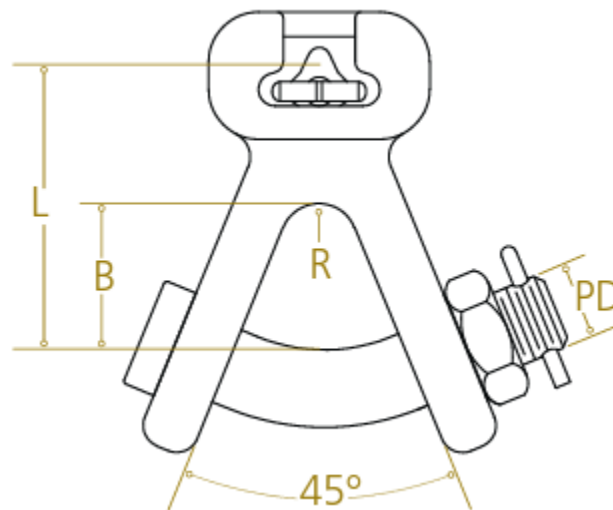

L Min.	B Min.	R Min.	PD
2 3/4"	1 9/16"	7/16"	3/4"

— End of Specification —











4752.278 Socket Y Clevis 30K

Final Audit Report

2022-08-18

Created:	2022-06-02
By:	Emmanuel E Rivera Cruz (emmanuel.riveracruz@lumapr.com)
Status:	Signed
Transaction ID:	CBJCHBCAABAA9Y1ldL3XD_NDIAGzC7QQwSrZlpimTKc

"4752.278 Socket Y Clevis 30K" History

-  Document created by Emmanuel E Rivera Cruz (emmanuel.riveracruz@lumapr.com)
2022-06-02 - 8:39:17 PM GMT
-  Document e-signed by Emmanuel E Rivera Cruz (emmanuel.riveracruz@lumapr.com)
Signature Date: 2022-06-02 - 8:40:50 PM GMT - Time Source: server
-  Document emailed to Rene Maldonado (rene.maldonado@lumapr.com) for signature
2022-06-02 - 8:40:52 PM GMT
-  Email viewed by Rene Maldonado (rene.maldonado@lumapr.com)
2022-06-02 - 8:40:55 PM GMT
-  Document e-signed by Rene Maldonado (rene.maldonado@lumapr.com)
Signature Date: 2022-06-03 - 12:26:05 PM GMT - Time Source: server
-  Document emailed to oscar.venegas@lumapr.com for signature
2022-06-03 - 12:26:07 PM GMT
-  Email viewed by oscar.venegas@lumapr.com
2022-06-03 - 12:26:13 PM GMT
-  Email viewed by oscar.venegas@lumapr.com
2022-06-05 - 12:31:27 PM GMT
-  Email viewed by oscar.venegas@lumapr.com
2022-06-08 - 12:31:29 PM GMT
-  Email viewed by oscar.venegas@lumapr.com
2022-06-09 - 12:31:27 PM GMT
-  Email viewed by oscar.venegas@lumapr.com
2022-06-11 - 12:31:25 PM GMT

 Email viewed by oscar.venegas@lumapr.com

2022-06-12 - 12:31:31 PM GMT

 Email viewed by oscar.venegas@lumapr.com

2022-08-10 - 3:39:58 PM GMT

 Signer oscar.venegas@lumapr.com entered name at signing as Oscar E Venegas

2022-08-10 - 3:47:49 PM GMT

 Document e-signed by Oscar E Venegas (oscar.venegas@lumapr.com)

Signature Date: 2022-08-10 - 3:47:51 PM GMT - Time Source: server- Signature captured from device with phone number XXXXXXX2079

 Document emailed to Walter Carrasquillo (walter.carrasquillo@lumapr.com) for signature

2022-08-10 - 3:47:52 PM GMT

 Email viewed by Walter Carrasquillo (walter.carrasquillo@lumapr.com)

2022-08-10 - 5:53:23 PM GMT

 Document e-signed by Walter Carrasquillo (walter.carrasquillo@lumapr.com)

Signature Date: 2022-08-10 - 5:54:10 PM GMT - Time Source: server

 Document emailed to Heriberto Gonzalez (heriberto.gonzalez@lumapr.com) for signature

2022-08-10 - 5:54:12 PM GMT

 Document e-signed by Heriberto Gonzalez (heriberto.gonzalez@lumapr.com)

E-signature obtained using URL retrieved through the Adobe Acrobat Sign API

Signature Date: 2022-08-18 - 1:28:36 PM GMT - Time Source: server

 Agreement completed.

2022-08-18 - 1:28:36 PM GMT