



Wedge Connector
556.5 – 3 / 0 ACSR

Equipment Specification
 Document No.: 4752.215
 Item No.: 002-81961
 Originating Dept: Transmission Eng.

	Document Title: Wedge Connector 556.5 – 3 / 0 ACSR	
	Document Type: Equipment Specification	Document No.: 4752.215
Department: Transmission Engineering	Version: 01	Effective Date: Dec 15, 2022

<p>Author Emmanuel E Rivera Cruz Designer, Transmission & Substation Engineering</p> <p>Reviewer 1 Rene Maldonado Supervisor, Line Engineering Standards</p> <p>Reviewer 2 Oscar Venegas Lead Engineer, Transmission Engineering</p> <p>Approver Walter Carrasquillo Alberty Manager, T&S Standards and Materials</p>	Signature and Date Emmanuel E Rivera Cruz (Dec 15, 2022 08:44 AST)
	Signature and Date Rene Maldonado (Dec 15, 2022 08:55 AST)
	Signature and Date Oscar E Venegas (Dec 21, 2022 11:36 AST)
	Signature and Date Walter Carrasquillo (Dec 21, 2022 13:06 AST)

Management Approval

Heriberto González Director, Transmission Line and Engineering Standards	Signature and Date Heriberto Gonzalez (Dec 21, 2022 14:33 AST)
---	---

Version History

Version	Date	Revision Comments	Author	Reviewers	Approver
00	July 12, 2021		Rene Maldonado	Heriberto Gonzalez	Walter Carrasquillo
01	Dec 21, 2022	General revision for final approval	Emmanuel E. Rivera	Rene Maldonado Oscar Venegas	Walter Carrasquillo



1 General

- 1.1. This specification describes the minimum requirements of wedge connector with power booster
- 1.2. The wedge connector shall be designed, rated, manufactured, and tested in accordance with the latest applicable IEEE, NEMA, ANSI, ASTM, and NEC Standards¹, If the Vendor does not demonstrate its compliance with the applicable standards, these specification requirements and supply the requested documents, the bid may be rejected.
- 1.3. The Vendor shall provide LUMA Energy with a list of recommended spare parts, tools, and service equipment, including prices.

2. Specific Name

- 2.1. Wedge connector (Run & Tap) for ACSR conductors – 3/0 & 556.5

3. Basic Use

- 3.1. For combination or connection of ACSR conductors at dead structures in 38 kV transmission lines.

4. Special Requirements

- 4.1. Samples shall be furnished if requested by LUMA.
- 4.2. LUMA may require one (1) unit properly labeled for testing and analysis.
- 4.3. Descriptive and technical literature shall be supplied if requested by LUMA.
- 4.4. Vendors that have supplied this material to PREPA in previous orders, will not have to furnish samples at bid opening.
- 4.5. They shall be required to show evidence of LUMA's approval of the equipment if requested.

5. Marking and packaging

- 5.1. Containers shall be marked outside with LUMA's purchase order number and code number.
- 5.2. Vendor shall prepare material and equipment for shipment in such a manner as to facilitate handling and protection from damage.

All material shall be packaged and marked in such a way that the receiving warehouse can readily identify and send in one (1) complete unit to a field location without opening crates or boxes to sort items and/or parts.

¹ IEEE = Institute of Electrical and Electronics Engineers
NEMA = National Electric Manufacturers Association
ANSI = American National Standard Institute
ASTM = American Society of Testing and Materials
NEC = National Electric Code.



6. Labeling

- 6.1. Each unit shall be clearly marked with the installation tool to be used, either with a color coding or numbering.

7. Equal or approved equal to:

- 7.1. Burndy Corp., Catalog number – WCY64PB
- 7.2. Ampact Tap Connectors – 1-602031-6

8. Number of pieces per package:

- 8.1. Each box with ten (10) connectors.

9. Description

- 9.1. Aluminum wedge connector that is power-driven between the run and tap cables ACSR locking them into a “C” shaped aluminum alloy spring body.
- 9.2. Installation tool – Burndy Corp., Catalog – Type WTRBYK,
Ampact Tool – AMPS-0-1443414-1 Large
- 9.3. Power Boosters – Yellow Coded
- 9.4. Shall accommodate the following conductor sizes:
Run Side: 556.5 ACSR (Parakeet)
Tap Side: 3 / 0 ACSR (Pigeon)

10. Inspection

- 10.1. The acceptance of any material or equipment shall in no way relieve the vendor from his responsibility to meet all the requirements of this specification, and it shall not prevent subsequent rejection if such material is found to be defective later.



11. Drawing

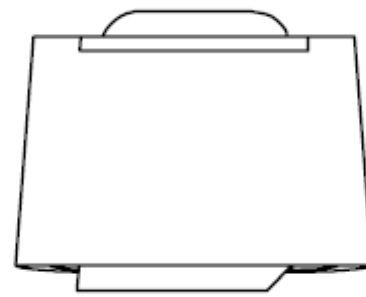
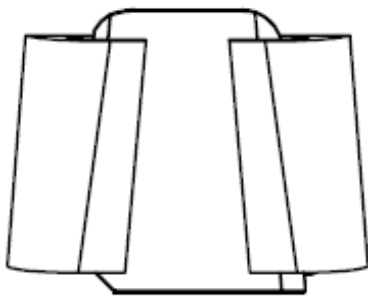
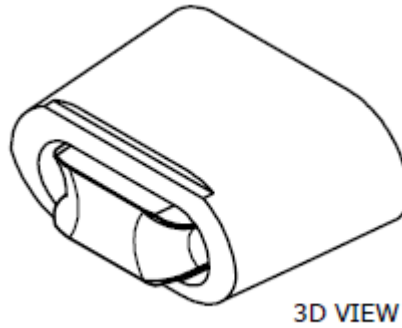

Dimensions

Sum of Diameters (in.)		Run (in.)		Tap (in.)	
Max	Min	Max	Min	Max	Min
1.421	1.216	0.940	0.683	0.650	0.436

— End of Specification —











4752.215 Wedge connector 556-3.0

Final Audit Report

2022-12-21

Created:	2022-12-15
By:	Leonardo Montes Sanchez (leonardo.montessanch@lumapr.com)
Status:	Signed
Transaction ID:	CBJCHBCAABAAmKfOd3WWA_E60c-M3YA0-Kez7d1bafMf

"4752.215 Wedge connector 556-3.0" History

-  Document created by Leonardo Montes Sanchez (leonardo.montessanch@lumapr.com)
2022-12-15 - 12:39:28 PM GMT
-  Document emailed to Emmanuel E Rivera Cruz (emmanuel.riveracruz@lumapr.com) for signature
2022-12-15 - 12:43:53 PM GMT
-  Email viewed by Emmanuel E Rivera Cruz (emmanuel.riveracruz@lumapr.com)
2022-12-15 - 12:44:36 PM GMT
-  Document e-signed by Emmanuel E Rivera Cruz (emmanuel.riveracruz@lumapr.com)
Signature Date: 2022-12-15 - 12:44:44 PM GMT - Time Source: server
-  Document emailed to Rene Maldonado (rene.maldonado@lumapr.com) for signature
2022-12-15 - 12:44:45 PM GMT
-  Email viewed by Rene Maldonado (rene.maldonado@lumapr.com)
2022-12-15 - 12:55:41 PM GMT
-  Document e-signed by Rene Maldonado (rene.maldonado@lumapr.com)
Signature Date: 2022-12-15 - 12:55:52 PM GMT - Time Source: server
-  Document emailed to oscar.venegas@lumapr.com for signature
2022-12-15 - 12:55:52 PM GMT
-  Email viewed by oscar.venegas@lumapr.com
2022-12-21 - 3:29:24 PM GMT
-  Signer oscar.venegas@lumapr.com entered name at signing as Oscar E Venegas
2022-12-21 - 3:35:59 PM GMT
-  Document e-signed by Oscar E Venegas (oscar.venegas@lumapr.com)
Signature Date: 2022-12-21 - 3:36:01 PM GMT - Time Source: server- Signature captured from device with phone number XXXXXXXX2079

 Document emailed to Walter Carrasquillo (walter.carrasquillo@lumapr.com) for signature

2022-12-21 - 3:36:02 PM GMT

 Email viewed by Walter Carrasquillo (walter.carrasquillo@lumapr.com)

2022-12-21 - 5:00:17 PM GMT

 Document e-signed by Walter Carrasquillo (walter.carrasquillo@lumapr.com)

Signature Date: 2022-12-21 - 5:06:36 PM GMT - Time Source: server

 Document emailed to Heriberto Gonzalez (heriberto.gonzalez@lumapr.com) for signature

2022-12-21 - 5:06:37 PM GMT

 Document e-signed by Heriberto Gonzalez (heriberto.gonzalez@lumapr.com)

E-signature obtained using URL retrieved through the Adobe Acrobat Sign API

Signature Date: 2022-12-21 - 6:33:12 PM GMT - Time Source: server

 Agreement completed.

2022-12-21 - 6:33:12 PM GMT