



**Wedge Stirrup Tap Connector**  
**556.5 ACSR**

**Equipment Specification**  
Document No.: 4752.214  
Item No.: 002-81958  
Originating Dept: Transmission Eng

	Document Title: <b>Wedge Stirrup Connector 556.4 ACSR</b>		
	Document Type: <b>Equipment Specification</b>	Document No.: <b>4752.214</b>	
Department: Transmission Engineering	Version: 01	Issue Date: 5/30/2022	Effective Date: 5/30/2022

<p><b>Author</b> Emmanuel E Rivera Cruz Designer, Transmission &amp; Substation Engineering</p> <p><b>Reviewer 1</b> Rene Maldonado Supervisor, Line Engineering Standards</p> <p><b>Reviewer 2</b> Oscar Venegas Lead Engineer, Trans</p> <p><b>Approver</b> Walter Carrasquillo Alberty Manager, T&amp;S Standards and Materials</p>	Signature and Date  <a href="#">Emmanuel E Rivera Cruz (Jun 6, 2022 13:33 EDT)</a>
	Signature and Date  <a href="#">Rene Maldonado (Jun 6, 2022 13:58 EDT)</a>
	Signature and Date  <a href="#">Oscar E Venegas (Jun 15, 2022 09:56 EDT)</a>
	Signature and Date  <a href="#">Walter Carrasquillo (Jun 15, 2022 15:54 EDT)</a>

<b>Management Approval</b>	
<p>Heriberto González Section Manager, Standards</p> <p>Darrel Wilvers Director, Asset Management</p>	Signature and Date  <a href="#">Heriberto Gonzalez (Jun 16, 2022 09:45 EDT)</a>
	Signature and Date <b>N/A</b>

<b>Version History</b>					
Version	Date	Revision Comments	Author	Reviewers	Approver
00	July 12, 2021		Rene Maldonado	Heriberto Gonzalez	Walter Carrasquillo
01	May 30, 2022	General revision for final approval	Emmanuel E. Rivera	Rene Maldonado Oscar Venegas	Walter Carrasquillo



## **1. General**

- 1.1. This specification describes the minimum requirements of wedge stirrup connector with power booster.
- 1.2. The wedge connector shall be designed, rated, manufactured, and tested in accordance with the latest applicable IEEE, NEMA, ANSI, ASTM, and NEC Standards<sup>1</sup>, If the Vendor does not demonstrate its compliance with the applicable standards, these specification requirements and supply the requested documents, the bid may be rejected.
- 1.3. The Vendor shall provide LUMA Energy with a list of recommended spare parts, tools, and service equipment, including prices.

## **2. Specific Name**

- 2.1. Wedge stirrup tap connector for 556.5 ACSR conductor

## **3. Basic Use**

- 3.1. For tap connection of ACSR conductor at dead structures in 38 kV distribution lines.

## **4. Special Requirements**

- 4.1. Samples shall be furnished if requested by LUMA.
- 4.2. LUMA may required one (1) unit properly labeled for testing and analysis.
- 4.3. Descriptive and technical literature shall be supplied if requested by LUMA.
- 4.4. Vendors that have supplied this material to PREPA in previous orders, will not have to furnish samples at bid opening.
- 4.5. They shall be required to show evidence of LUMA's approval of the equipment if requested.

## **5. Marking and packaging**

- 5.1. Containers shall be marked outside with LUMA's purchase order number and code number.
- 5.2. Vendor shall prepare material and equipment for shipment in such a manner as to facilitate handling and protection from damage.

All material shall be packaged and marked in such a way that the receiving warehouse can readily identify and send in one (1) complete unit to a field location without opening crates or boxes to sort items and/or parts.

---

<sup>1</sup> IEEE = Institute of Electrical and Electronics Engineers  
NEMA = National Electric Manufacturers Association  
ANSI = American National Standard Institute  
ASTM = American Society of Testing and Materials  
NEC = National Electric Code.



**6. Labeling**

- 6.1. Each unit shall be clearly marked with the installation tool to be used, either with a color coding or numbering.

**7. Equal or approved equal to:**

- 7.1. Burndy Corp., Catalog number – WSL7PB
- 7.2. Ampact Catalog Number – 602104

**8. Number of pieces per package:**

- 8.1. Each box with ten (5) connectors.

**9. Description**

- 9.1. Aluminum wedge connector that is used to install tap connections which must be removed and reinstalled frequently.
- 9.2. Installation tool – Burndy Corp., Catalog – Type WTRBYK,  
Ampact Tool – AMPS-0-1443414-1 Large
- 9.3. Power Boosters – Yellow Coded

**10. Inspection**

- 10.1. The acceptance of any material or equipment shall in no way relieve the vendor from his responsibility to meet all the requirements of this specification, and it shall not prevent subsequent rejection if such material is found to be defective later.

**11. Drawing**

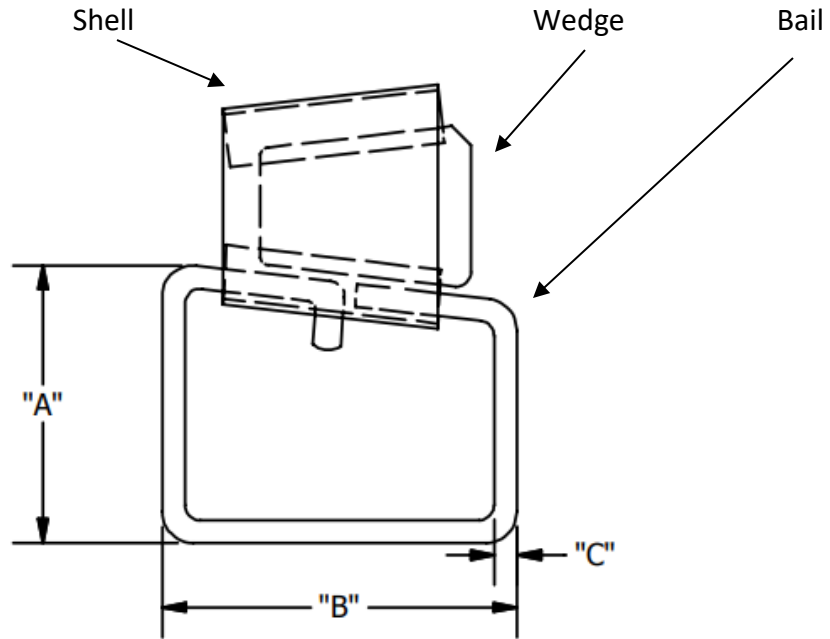

**Dimensions**

Catalog #	Nominal Cable Range	Bail Size	"A" Length (in.)	"B" Length (in.)	"C" Length (in.)
WSL7	556.5	1 / 0	4.50	5.46	0.46

— End of Specification —











# 4752.214 Wedge connector 556 w stirrup

Final Audit Report

2022-06-16

Created:	2022-06-06
By:	Emmanuel E Rivera Cruz (emmanuel.riveracruz@lumapr.com)
Status:	Signed
Transaction ID:	CBJCHBCAABAAAd6zJsDlotpbk1uJTW5vgMWL6JeKbEsbl

## "4752.214 Wedge connector 556 w stirrup" History

-  Document created by Emmanuel E Rivera Cruz (emmanuel.riveracruz@lumapr.com)  
2022-06-06 - 5:31:01 PM GMT
-  Document e-signed by Emmanuel E Rivera Cruz (emmanuel.riveracruz@lumapr.com)  
Signature Date: 2022-06-06 - 5:33:07 PM GMT - Time Source: server
-  Document emailed to Rene Maldonado (rene.maldonado@lumapr.com) for signature  
2022-06-06 - 5:33:09 PM GMT
-  Email viewed by Rene Maldonado (rene.maldonado@lumapr.com)  
2022-06-06 - 5:58:35 PM GMT
-  Document e-signed by Rene Maldonado (rene.maldonado@lumapr.com)  
Signature Date: 2022-06-06 - 5:58:56 PM GMT - Time Source: server
-  Document emailed to Oscar E Venegas (oscar.venegas@lumapr.com) for signature  
2022-06-06 - 5:58:58 PM GMT
-  Email viewed by Oscar E Venegas (oscar.venegas@lumapr.com)  
2022-06-11 - 6:02:18 PM GMT
-  Email viewed by Oscar E Venegas (oscar.venegas@lumapr.com)  
2022-06-12 - 6:02:05 PM GMT
-  Email viewed by Oscar E Venegas (oscar.venegas@lumapr.com)  
2022-06-13 - 6:02:08 PM GMT
-  Email viewed by Oscar E Venegas (oscar.venegas@lumapr.com)  
2022-06-14 - 6:02:13 PM GMT
-  Document e-signed by Oscar E Venegas (oscar.venegas@lumapr.com)  
Signature Date: 2022-06-15 - 1:56:16 PM GMT - Time Source: server- Signature captured from device with phone number XXXXXXXX2079

 Document emailed to Walter Carrasquillo (walter.carrasquillo@lumapr.com) for signature

2022-06-15 - 1:56:18 PM GMT

 Email viewed by Walter Carrasquillo (walter.carrasquillo@lumapr.com)

2022-06-15 - 1:56:22 PM GMT

 Document e-signed by Walter Carrasquillo (walter.carrasquillo@lumapr.com)

Signature Date: 2022-06-15 - 7:54:51 PM GMT - Time Source: server

 Document emailed to Heriberto Gonzalez (heriberto.gonzalez@lumapr.com) for signature

2022-06-15 - 7:54:53 PM GMT

 Email viewed by Heriberto Gonzalez (heriberto.gonzalez@lumapr.com)

2022-06-15 - 7:54:56 PM GMT

 Document e-signed by Heriberto Gonzalez (heriberto.gonzalez@lumapr.com)

E-signature obtained using URL retrieved through the Adobe Acrobat Sign API

Signature Date: 2022-06-16 - 1:45:38 PM GMT - Time Source: server

 Agreement completed.

2022-06-16 - 1:45:38 PM GMT