



Document Title:

**Guy Cone 19#5**

Document Type:

**Equipment Specification**

Document No.:

**4752.211**

Department:

Transmission Engineering

Version:

02

Effective Date:

Jun 28, 2023

Shared document with:  T&S  T&D  T&TM  D&TM

**Author**

Emmanuel E Rivera Cruz  
EIT, Transmission Line Engineering

Signature and Date

[Emmanuel E Rivera Cruz \(Jun 28, 2023 12:34 EDT\)](#)

**Reviewer**

Leonardo Montes Sánchez  
EIT, T&S Standards & Materials

Signature and Date

[Leonardo Montes Sanchez \(Jun 29, 2023 10:13 EDT\)](#)

**Approver**

René Maldonado, P.E. (Lic #18435)  
Supervisor, Transmission Line Engineering Standards

Signature and Date

[Rene Maldonado \(Jun 29, 2023 10:38 EDT\)](#)

**Version History**

Version	Date	Revision Comments
00	Dec 28, 2021	First Issue
01	May 26, 2022	General revision for final approval
02	Jun 29, 2023	Coating color correction to green Section 9.6.2.



**1. General**

- 1.1. This is a general specification that covers the minimum requirements for a Guy Cone 19#5 to be used in the transmission system in Puerto Rico.
- 1.2. Further information will be provided by LUMA Energy at the time of order placement and will provide information on site conditions, quantity, and other requirements.
- 1.3. This document includes the general electrical and mechanical characteristics of the material.

**2. Specific Name**

- 2.1. Guy Cone 19#5.

**3. Basic Use**

- 3.1. For control of climbing plants on poles and structures tensioning cables, on the transmission line structures.

**4. Special Requirements**

- 4.1. Samples shall be furnished if requested by LUMA.
- 4.2. LUMA may require one (1) unit properly labeled for testing and analysis.
- 4.3. Descriptive and technical literature shall be supplied if requested by LUMA.

**5. Marking and Packaging**

- 5.1. All material and equipment shall be packaged and marked in such a way as to facilitate handling and protection from damage and that the receiving warehouse can readily identify it and send it, in one complete unit, to a field location without opening crates or boxes to sort items and/or parts.

**6. Equal or approved equal to:**

- 6.1. As approved by LUMA.

**7. Number per package:**

- 7.1. Package quantity: 16 units, or approved by LUMA.

**8. Acceptance Criteria**

- 8.1. Latest applicable codes, standards, and other regulations: ANSI/ASTM.



## 9. Description

- 9.1. Galvannealed steel cone for control of climbing plants on 19#5 guy wire (Diam. 0.937 in.).
- 9.2. Material shall be 0.022 in. minimum thickness galvannealed steel as per ASTM A-653. The cone shall be cut in half and a reinforcing welded bracket shall be included according with the drawing.
- 9.3. The cone shall be cut in half and a reinforcing welded bracket shall be included according with the drawing.
- 9.4. It shall also include two (2) stainless steel clamps to adjust the 0.937 in. diameter tube at the cone center.
- 9.5. Two (2) 7/32 x 1 in. stainless steel screws with washer and nut shall be also included.
- 9.6. A three (3) stage painting process shall be applied to both surfaces (interior and exterior), equal or equivalent to the following application:
  - 9.6.1. Phase 1: Alkaline degreaser cleaning, electro cleaning and water (ro) rinsing prior to iron phosphate coating.
  - 9.6.2. Phase 2: Barium free paint coating powder polyester or other equivalent powder coating. The color of this paint shall be green as per latest ANSI/IEEE C57.12.28 (section 5.2.4): Munsell Number "7GY 3.29/1.5 high gloss" or "7GY 3.29/1.5 SG semi-gloss" pad-mount green. The color variation of the coated product shall not exceed the Munsell Color Standard by more than a  $\Delta E$  (Hunter) value of four.

Equal or approved paint:

    - a. ICI Paints - Glidden (S/C green, base 4308-0900, Blk 4P13, Yox 5P58, Tbl 3P5, Wht 51)
    - b. Mobile Paints (014204004 RUS-KIL match general green)
    - c. Sherwin-Williams Paints (B54T104, S/C olive green)
  - 9.6.3. Phase 3: Drying process. Oven temperature controlled at 400° f. Parts exposed till cured cooling time as needed.
- 9.7. Metric conversion as per latest ASTM.

## 10. Inspection

- 10.1. The acceptance of any material or equipment shall in no way relieve the vendor from his responsibility to meet all the requirements of this specification, and it shall not prevent subsequent rejection if such material is found to be defective later.

11. Drawing

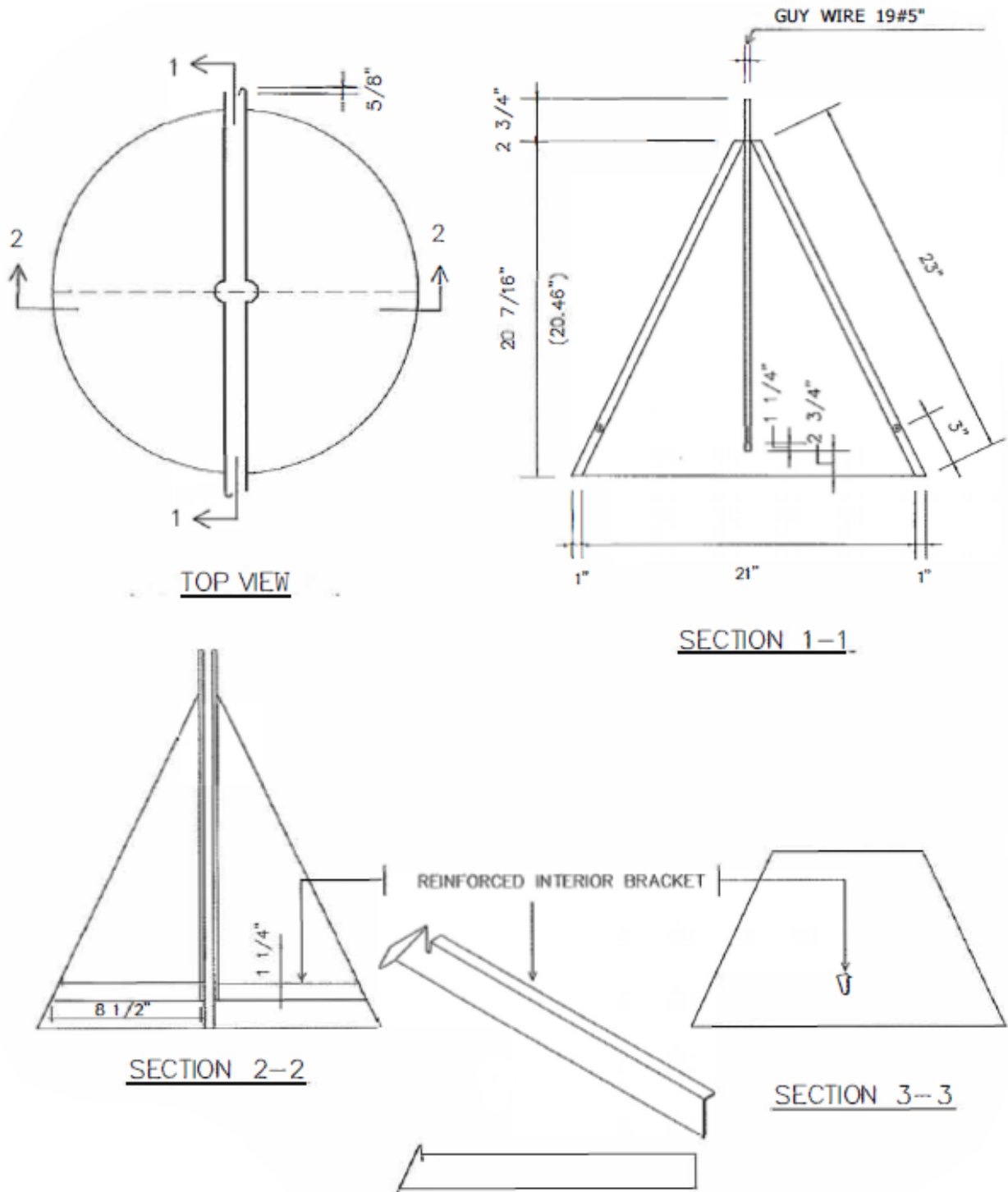

— End of Specification —











# 4752.211 GUY CONE 19#5

Final Audit Report

2023-06-29

Created:	2023-06-28
By:	Emmanuel E Rivera Cruz (emmanuel.riveracruz@lumapr.com)
Status:	Signed
Transaction ID:	CBJCHBCAABAACDVStikqx3GnL9ESIIKrrl3eaTbBnQR6

## "4752.211 GUY CONE 19#5" History

-  Document created by Emmanuel E Rivera Cruz (emmanuel.riveracruz@lumapr.com)  
2023-06-28 - 4:32:49 PM GMT
-  Document e-signed by Emmanuel E Rivera Cruz (emmanuel.riveracruz@lumapr.com)  
Signature Date: 2023-06-28 - 4:34:27 PM GMT - Time Source: server
-  Document emailed to leonardo.montessanch@lumapr.com for signature  
2023-06-28 - 4:34:28 PM GMT
-  Email viewed by leonardo.montessanch@lumapr.com  
2023-06-29 - 2:10:07 PM GMT
-  Signer leonardo.montessanch@lumapr.com entered name at signing as Leonardo Montes Sanchez  
2023-06-29 - 2:13:32 PM GMT
-  Document e-signed by Leonardo Montes Sanchez (leonardo.montessanch@lumapr.com)  
Signature Date: 2023-06-29 - 2:13:34 PM GMT - Time Source: server- Signature captured from device with phone number XXXXXXXX5488
-  Document emailed to Rene Maldonado (rene.maldonado@lumapr.com) for signature  
2023-06-29 - 2:13:35 PM GMT
-  Email viewed by Rene Maldonado (rene.maldonado@lumapr.com)  
2023-06-29 - 2:38:13 PM GMT
-  Document e-signed by Rene Maldonado (rene.maldonado@lumapr.com)  
Signature Date: 2023-06-29 - 2:38:22 PM GMT - Time Source: server
-  Agreement completed.  
2023-06-29 - 2:38:22 PM GMT