



**Polymer Line Post Insulator
38, 115 & 230 kV**

Equipment Specification
Document No.: 4752.199
Item No.:
Originating Dept: Transmission Eng.

	Document Title: Polymer Line Post Insulator 38, 115 & 230 kV		
	Document Type: Equipment Specification	Document No.: 4752.199	
Department: Transmission Engineering	Version: 01	Issue Date: 5/24/2022	Effective Date: 5/24/2022

<p>Author Emmanuel E Rivera Cruz Designer, Transmission & Substation Engineering</p> <p>Reviewer 1 Rene Maldonado Supervisor, Line Engineering Standards</p> <p>Reviewer 2 Oscar Venegas Lead Engineer, Trans</p> <p>Approver Walter Carrasquillo Alberty Manager, T&S Standards and Materials</p>	Signature and Date Emmanuel E Rivera Cruz (Jun 13, 2022 14:32 EDT)
	Signature and Date Rene Maldonado (Jun 14, 2022 09:50 EDT)
	Signature and Date Oscar E Venegas (Jun 21, 2022 16:53 EDT)
	Signature and Date Walter Carrasquillo (Jun 22, 2022 09:03 EDT)

Management Approval	
<p>Heriberto González Section Manager, Standards</p> <p>Darrel Wilvers Director, Asset Management</p>	Signature and Date Heriberto Gonzalez (Jun 22, 2022 13:05 EDT)
	Signature and Date N/A

Version History					
Version	Date	Revision Comments	Author	Reviewers	Approver
00	Dec 28, 2021		Rene Maldonado	Heriberto Gonzalez	Walter Carrasquillo
01	May 24, 2022	General revision for final approval	Emmanuel E. Rivera	Rene Maldonado Oscar Venegas	Walter Carrasquillo



1. General

- 1.1. This specification describes the minimum requirements for the design, manufacturing, testing, and supply of silicone rubber composite line post insulators to be used in the transmission lines in Puerto Rico.
- 1.2. Further information will be provided by LUMA Energy at the time of order placement and will provide information on site conditions, quantity, and other requirements.

2. Specific Name

- 2.1. Polymer Line Post Insulator for Transmission System.

3. Basic Use

- 3.1. The line post insulator is used for mechanical support and insulation on overhead transmission lines.

4. Special Requirements

- 4.1. Samples shall be furnished if requested by LUMA.
- 4.2. LUMA may require One (1) unit properly labeled for testing and analysis.
- 4.3. Descriptive and technical literature shall be supplied if requested by LUMA.
- 4.4. They shall be required to show evidence of LUMA's approval of the equipment if requested.

5. Marking

- 5.1. Each composite insulator shall bear a marking in accordance with ANSI Standards, identifying the following:
 - 5.1.1. Manufacturer's Name.
 - 5.1.2. Manufacturer's Catalog Number.
 - 5.1.3. Year of Manufacture.
 - 5.1.4. Specified Mechanical Load (S.M.L.).
- 5.2. The marking shall be legible and durable. The use of labels is not permitted.
- 5.3. Containers shall be marked outside with LUMA's purchase order number and code number.



6. Packaging / Labeling

- 6.1. All material and equipment shall be packaged and marked in such a way as to facilitate handling and protection from damage and that the receiving warehouse can readily identify it and send it, in one complete unit, to a field location without opening crates or boxes to sort items and/or parts.
- 6.2. Insulators shall be shipped in boxes or crates with units supported by end fittings. At least one intermediate support is required for 230 kV units.
- 6.3. Handling instructions shall be shipped inside each box or crate.
- 6.4. Corona rings shall be packaged and shipped on separate compartments of the crate or box containing the insulators. Drawings showing the installation procedure and correct position of the corona ring shall be shipped inside the crate or box.
- 6.5. Crates or boxes walls shall be protected against rodents.
- 6.6. Crates or boxes shall be lined to protect insulators from dirt and dust.
- 6.7. Packaging labels and tags shall be waterproof. Clear weatherproof containers are required for each insulator. The containers shall be removable by hand.

7. Equal or approved equal to:

- 7.1. As approved by LUMA.

8. Number per package:

- 8.1. As requested by LUMA.

9. Acceptance Criteria

- 9.1. Latest applicable codes, standards, and other regulations:
 - 9.1.1. ANSI C29.1 Test Methods for Electrical Power Insulators.
 - 9.1.2. ANSI C29.11 Standard for Composite Suspension Insulators for Overhead Transmission Lines Test.
 - 9.1.3. ANSI C29.18: for composite line post insulators made of a fiberglass-reinforced resin matrix core, elastomeric material weathersheds and metal end fittings.
 - 9.1.4. ANSI 987 IEEE Guide for Application of Composite Insulators.
 - 9.1.5. IEC 61109 Composite Insulators for AC Overhead Lines with a Minimal Voltage Greater than 1,000 volts, Definitions, Test Methods, and Criteria.
 - 9.1.6. ASTM A153 Zinc Coating (Hot-Dip) on Iron and Steel Hardware.



10. Description

- 10.1. Temperature & Humidity: The equipment supplied shall be adequate for an operating temperature range of 5°C to 40°C (41 to 104 °F), with humidity up to 100%.
- 10.2. Line post insulators shall have an end fitting suitable to install a top clamp for the conductor specified. Top clamp shall be included, so it can be used with copper and aluminum conductors, with clamping range for a ACSR conductor overall diameter from 0.914" to 1.667".
- 10.3. The composite insulators shall have the parameters included on Table 1.
- 10.4. 38kV line post insulators shall have a base support that accepts 5/8" pole mounting bolts. Shall have at least of 2 holes, 12" minimum distance between holes center-to-center, suitable to be mounted on a 12" holes pole pattern.
- 10.5. 115 & 230kV line post insulators shall have a flat base support and must fit into the Post Insulator Bracket Assembly, as per Figure 1.
- 10.6. The manufacturer's probable true values for the dry and wet low frequency flashover, and for the positive and negative critical impulse flashover shall include the corona ring effect and shall be in the range specified by Table 1.
- 10.7. If a corona ring is necessary, the manufacturer's probable true values for the dry and wet low frequency flashover and for the positive and negative critical impulse flashover shall include the corona ring effect and shall be in the range specified by Table 1.
- 10.8. The maximum diameter of the insulator weathershed (including grading ring, if provided) shall not exceed 14 inches.
- 10.9. LUMA requires corona rings for all 230 kV insulators.
- 10.10. **Material:**
 - 10.10.1. The complete composite insulator shall consist of a core, housing (includes sheath and shed), and metal end fittings.
 - 10.10.2. The housing material shall be made of 100% silicone rubber prior to the addition of fillers.
 - 10.10.3. The polymer sheath and weather sheds shall be made of a material resistant to ultraviolet (UV) radiation exposure.
 - 10.10.4. Steel parts, except cotter pin, shall have the strength to withstand the load specified with the applicable safety factors.
 - 10.10.5. The coating of steel parts shall be as follows:
 - 10.10.5.1. Galvanizing shall be made after complete fabrication in accordance with ASTM A153. The fabricated product after galvanizing shall be free and clear of acid drops, tear drop membrane, clean, attractive, and unscarred when received. Pieces having galvanizing which does not meet these requirements shall be rejected.



- 10.10.6. The continuity of the coating application shall be in accordance with the test method described in ASTM A239 (six successive baths required).
- 10.10.7. The insulator shall be provided with high temperature vulcanized silicone rubber weathersheds, vulcanized or bonded to the fiberglass rod at intervals to provide optimum electrical performance. The strength of the silicone rubber to the rod interface shall be greater than the tearing strength of the silicone rubber.
- 10.10.8. No radial joints shall be made along the length of the sheath regardless of the distance between the end fittings. The sheath of pre-molded sheath with weather shed shall be extended inside the end fittings to protect the fiberglass core from moisture and to eliminate the possibility of discharge at joints.
- 10.10.9. The thickness of the sheath or weather shed covering over the rod shall not be less than $\frac{1}{8}$ ".
- 10.10.10. Cotter pin shall be made from cold drawn wire of bronze, brass, or stainless steel.
- 10.10.11. The reinforced fiberglass core shall consist of glass fibers in a resin matrix and shall be designed to withstand temperatures above 160° C without loss of its electrical and mechanical properties.
- 10.11. Tests:**
- 10.11.1. The composite insulators shall be tested in accordance with ANSI C29. 11, ANSI C2 9.1, CSA 411.1, and IEC 61109 standards.
- 10.11.2. Prototype tests shall be done on composite insulators of new designs in four (4) parts as described on section 7 of ANSI C29 .11. Each part may be performed independently on new test specimens. The test specimens shall pass the tests in each part in sequence. Prototype tests are to be performed for each class of insulator to verify the suitability of the prototype design, materials, and method of manufacture.
- 10.11.3. Certified reports of prototype tests performed on complete insulator of identical similar class by an independent Test Laboratory shall be submitted for review and acceptance by LUMA in line up of the actual prototype tests.
- 10.11.4. Type or Design tests shall be performed on composite insulators of new design, to verify those characteristics of a composite insulator which depend on its size and shape.
- 10.11.5. Certified reports of design or type tests, performed on complete insulator of identical design by an independent Test Laboratory, shall be submitted for review and acceptance by LUMA in lieu of the actual design or type tests.
- 10.11.6. The insulator, including all its hardware assembly, shall be tested in a suitable high voltage laboratory to demonstrate that the Corona Extinction Voltage (CEV) is greater than 1.2 times the maximum system operating voltage. If a corona ring is necessary, its surface shall be representative of actual LUMA field conditions.
- 10.11.7. The Manufacturer shall submit evidence of the Multi-Stress laboratory test reports as per IEC 61109 for the insulator rating specified in the purchase requisition.
-

- 10.11.8. The manufacturer shall submit evidence of dye penetration laboratory test reports as per CSA 411.4.
- 10.11.9. Quality conformance tests shall be performed at random on insulators selected from the lot to be supplied to LUMA.
- 10.11.10. Routine tests shall be performed on each insulator.
- 10.11.11. The Supplier shall provide certified copies of the factory tests results reports.

11. Inspection

- 11.1. The acceptance of any material or equipment shall in no way relieve the vendor from his responsibility to meet all the requirements of this specification, and it shall not prevent subsequent rejection if such material is found to be defective later.

12. Drawing



TABLE 1

Polymer Line Post Insulators for Transmission System			
Parameters	System Voltage		
	38 kV	115 kV	230 kV
Min. Leakage Distance	46 in.	125 in.	220 in
Min. Dry Arc Distance	20 in	50 in	78 in
Dry Low Freq. Avg. Flashover	175 kV	460 kV	720 kV
Wet Low Freq. Avg. Flashover	160 kV	410 kV	630 kV
Pos. Critical Imp. F.O.	260 kV	800 kV	1240 kV
Neg. Critical Imp. F.O.	380 kV	900 kV	1300 kV
Length	25 in. Aprox	60 in.	88 in.
Cantilever Force	1600 Lbs	1600 Lbs	1600 Lbs
Warehouse Code No.	014-01975	014-00779	014-02015



**Polymer Line Post Insulator
38, 115 & 230 kV**

Equipment Specification
Document No.: 4752.199
Item No.:
Originating Dept: Transmission Eng.

FIGURE 1

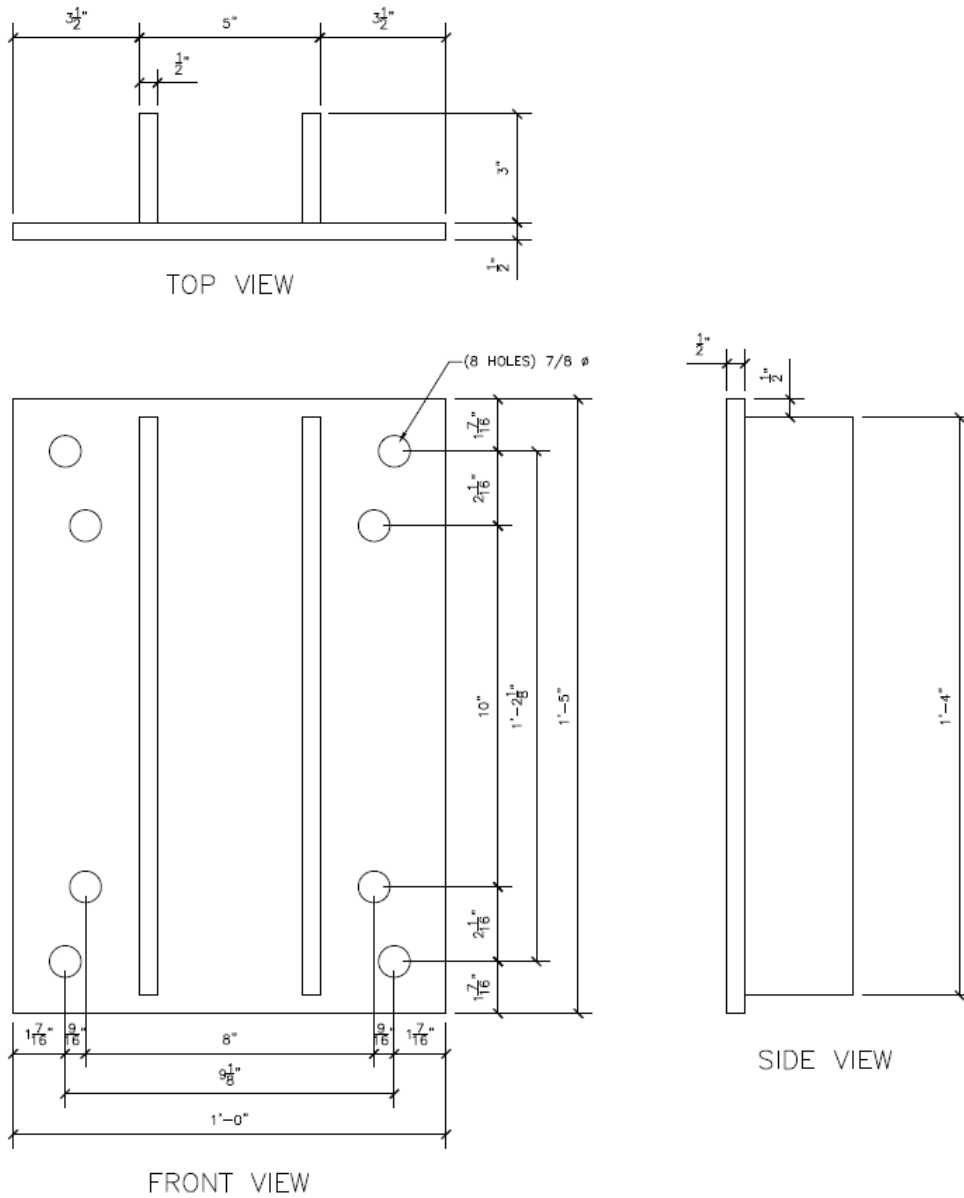

Post Insulator Bracket Assembly 115 & 230 kV

— End of Specification —

4752.199 Polimer Line Post Insulator 38, 115 & 230 kV

Final Audit Report

2022-06-22

Created:	2022-06-13
By:	Emmanuel E Rivera Cruz (emmanuel.riveracruz@lumapr.com)
Status:	Signed
Transaction ID:	CBJCHBCAABAAi7TnVHk9FsCGKNWhW5IHV_EdM5jgJVon

"4752.199 Polimer Line Post Insulator 38, 115 & 230 kV" History

 Document created by Emmanuel E Rivera Cruz (emmanuel.riveracruz@lumapr.com)
2022-06-13 - 6:31:15 PM GMT

 Document e-signed by Emmanuel E Rivera Cruz (emmanuel.riveracruz@lumapr.com)
Signature Date: 2022-06-13 - 6:32:40 PM GMT - Time Source: server

 Document emailed to Rene Maldonado (rene.maldonado@lumapr.com) for signature
2022-06-13 - 6:32:42 PM GMT

 Email viewed by Rene Maldonado (rene.maldonado@lumapr.com)
2022-06-13 - 6:32:45 PM GMT

 Document e-signed by Rene Maldonado (rene.maldonado@lumapr.com)
Signature Date: 2022-06-14 - 1:50:58 PM GMT - Time Source: server

 Document emailed to oscar.venegas@lumapr.com for signature
2022-06-14 - 1:51:01 PM GMT

 Email viewed by oscar.venegas@lumapr.com
2022-06-14 - 1:51:07 PM GMT

 Email viewed by oscar.venegas@lumapr.com
2022-06-15 - 1:55:44 PM GMT

 Email viewed by oscar.venegas@lumapr.com
2022-06-16 - 1:55:48 PM GMT

 Email viewed by oscar.venegas@lumapr.com
2022-06-17 - 1:55:47 PM GMT

 Email viewed by oscar.venegas@lumapr.com

2022-06-18 - 1:55:42 PM GMT

 Email viewed by oscar.venegas@lumapr.com

2022-06-19 - 1:55:41 PM GMT

 Email viewed by oscar.venegas@lumapr.com

2022-06-20 - 1:55:50 PM GMT

 Email viewed by oscar.venegas@lumapr.com

2022-06-21 - 1:55:43 PM GMT

 Document e-signed by Oscar E Venegas (oscar.venegas@lumapr.com)

Signature Date: 2022-06-21 - 8:53:11 PM GMT - Time Source: server- Signature captured from device with phone number XXXXXXXX2079

 Document emailed to Walter Carrasquillo (walter.carrasquillo@lumapr.com) for signature

2022-06-21 - 8:53:13 PM GMT

 Email viewed by Walter Carrasquillo (walter.carrasquillo@lumapr.com)

2022-06-21 - 8:53:20 PM GMT

 Document e-signed by Walter Carrasquillo (walter.carrasquillo@lumapr.com)

Signature Date: 2022-06-22 - 1:03:27 PM GMT - Time Source: server

 Document emailed to Heriberto Gonzalez (heriberto.gonzalez@lumapr.com) for signature

2022-06-22 - 1:03:29 PM GMT

 Email viewed by Heriberto Gonzalez (heriberto.gonzalez@lumapr.com)

2022-06-22 - 1:03:37 PM GMT

 Document e-signed by Heriberto Gonzalez (heriberto.gonzalez@lumapr.com)

Signature Date: 2022-06-22 - 5:05:59 PM GMT - Time Source: server

 Agreement completed.

2022-06-22 - 5:05:59 PM GMT