



Document Title:

**Remote Cable Operator for Underground Switchgear**

Document Type:

**Equipment Specifications**

Document No.:

**4350.314**

Originating Department:

**Distribution Standards & Materials**

Version:

**2**

Effective Date:

**Sep 15, 2023**

Shared documents:  T&S  T&D  T&TM  D&TM  HSE  Luma Engineering

<b>Author</b> Rodolfo A Flores Ortiz, PE General Engineer, Distribution Standards & Materials	Signature 	Date <b>Sep 15, 2023</b>
<b>Reviewer</b> Rafael Torres Martinez, PE Supervisor, Distribution Standards & Materials	Signature 	Date <b>Sep 15, 2023</b>
<b>Approver</b> Ricardo Castro Gómez, PE Manager, Distribution Standards & Materials	Signature 	Date <b>Sep 15, 2023</b>

## Version History

Date	Revision Comments
Aug. 03, 2023	Initial Release.
Sep 15, 2023	Revision of standard package information.

Item Description	Warehouse Catalog	Item Version	Date
Remote cable operator assembly with two cable operating handle mounted on a stainless-steel dual cable operator base, 2-20' ball bearing supported flexible control cable, and cable to switchgear handle brackets.	038-84651	2	09/15/2023



**Equipment Specification**

Document No.: 4350.314

Item No.: 038-84651

Asset Suite: 84651

Originating Department: Distribution Engineering

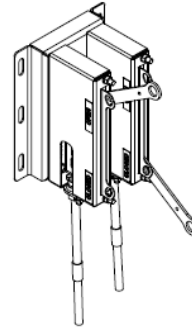

**Remote Cable Operator  
for Underground Switchgear**

---

**1. Introduction**

This is a general specification that covers the minimum requirements for the remote cable operator for underground switchgear to be used in the distribution system in Puerto Rico. Further information will be provided by LUMA Energy at the time of order placement and will provide information on site specific conditions, quantity, and other requirements. This document includes the general electrical and mechanical characteristics of the material.

**2. Special Requirements**

- 2.1. Samples shall be furnished as requested by LUMA Energy. Vendors that have supplied this material to LUMA on previous orders will not have to furnish samples at bid opening. The equipment/material will be received at the LUMA's general warehouse (011) at Palo Seco, Puerto Rico. Shipping will include transportation and unloading at the indicated warehouse.
- 2.2. Product shall be manufactured in accordance with the latest issue ASTM, NEMA, IEEE and ANSI specification. When conflicts occur between purchaser's specifications and the ASTM, NEMA, IEEE, or ANSI specifications, the purchaser's specification shall prevail. The product shall be furnished as described here in this specification or as amended by the purchase order. In the event of any changes or updates to the supplier's procedures, quality routines, and/or inspection layout the supplier shall be responsible for all costs incurred for the product that is rejected.
- 2.3. Upon inspection of incoming material, the purchaser reserves the right to refuse product shipments and to determine the acceptability or rejection of the product received. The supplier shall be liable for all costs incurred for the product that is rejected.
- 2.4. Any changes or updates to the supplier's approved designs, procedures, quality routines and/or inspection layout shall be communicated to LUMA Energy's material specification engineer in writing.

**3. Literature**

Descriptive and technical literature must be supplied by the vendor at time of bidding. This literature may include, but is not limited to details of material, drawings, documented testing, and instructions for use and installation. Failure to submit documents on time will cause bidder disqualification.



**Equipment Specification**

Document No.: 4350.314

Item No.: 038-84651

Asset Suite: 84651

Originating Department: Distribution Engineering

**Remote Cable Operator  
for Underground Switchgear**

---

**4. Markings**

- 4.1. Containers shall be marked outside with LUMA Energy's purchase order and item number, manufacturer's details such as model name and number, lot number, and the warehouse ID number where it will be received at.
- 4.2. Packaging labels and tags shall be waterproof.

**5. Compatible with:**

- 5.1. Trayer Engineering Corp. – Catalog Number: 720-C20LLRR-01
- 5.2. This model is an example of the material described in this document and does not represent a preference. LUMA will evaluate equally any model not listed here during any acquisition event.

**6. Packaging**

All material and equipment shall be packaged and marked in such a way as to facilitate handling and protection from damage and that the receiving warehouse can readily identify it and send it, in one complete unit, to a field location without opening crates or boxes to sort items and/or parts.

**7. Number Per Package (Logistics)**

- 7.1. Two operators per package or as requested by LUMA. The operators shall conform:
  - a. 4 handles (2 per operator)
  - b. 4 cables 20 ft long each (2 per operator)
  - c. Hardware for 4 handles and cable
  - d. Brackets to mount to the switchgear for both left and right side mounting.

**8. Acceptance Criteria**

- 8.1. Test required: certified by external laboratories.
- 8.2. Shall comply with the latest applicable codes, standards, and other regulations.



### Equipment Specification

Document No.: 4350.314

Item No.: 038-84651

Asset Suite: 84651

Originating Department: Distribution Engineering

## Remote Cable Operator for Underground Switchgear

---

### 9. Description

- 9.1. Remote cable operators are used to operate underground switchgear from the manhole exterior. This substantially increase safety and speed up the operation time because there is no need to enter to a manhole to make a switchgear operation.
- 9.2. The remote cable operator consists of two cable operating handles mounted on a stainless-steel dual cable operator base. Each cable operating handle is connected to a 20' (6.096 m) ball bearing supported flexible control cable with a connection bracket in the other end for switch operating handle connection.
- 9.3. Each remote cable operator shall be capable of operating two control cables (2 switchgear ways).
- 9.4. All components of the remote cable operator shall be made of stainless steel 18-8 or better. Nuts and washer can be made of bronze or brass.
- 9.5. The cable operating handle must allow vertical or horizontal hotstick operation, must be padlockable to prevent inadvertent operation, and shall indicate the switch position, which shall be clearly visible from the normal operating position.
- 9.6. The remote cable operators must have approximately the following dimensions:
  - a) Height: 11 3/4" (29.85 cm)
  - b) Wide: 9 1/2" (24.13 cm)
- 9.7. Remote cable operator handles extension must not exceed in any position 15" (38.1 cm) from the remote cable operator base. Refer to Figure A for equipment dimensions.
- 9.8. The cable operator base shall have at least 4 mounting slots (one near each base corner) with the following dimensions 1" (25.4 mm) x 5/16" (7.94 mm) that can accept 1/4" (6.35 mm)  $\phi$  concrete screw anchor.
- 9.9. The control cable shall be a ball bearing supported flexible control cable type.
- 9.10. The control cable shaft must be made of stainless steel and the cable sheath can be made of brass or stainless steel.
- 9.11. The control cable ends shall be furnished with swivel abutment that permit rotation during operation.



**Equipment Specification**

Document No.: 4350.314

Item No.: 038-84651

Asset Suite: 84651

Originating Department: Distribution Engineering

**Remote Cable Operator  
for Underground Switchgear**

---

- 9.12. The control cable end that goes to the switchgear must be furnished with an "L" shape bracket for the switchgear handle connection. This bracket must accept 3/8"  $\phi$  hex head bolt for the switchgear handle connection.
- 9.13. The control cable shaft travel shall be 3 1/2" (8.89 cm) when remote cable operator handle moves from off to on position or vice versa.
- 9.14. Figure A:



**Equipment Specification**

Document No.: 4350.314

Item No.: 038-84651

Asset Suite: 84651

Originating Department: Distribution Engineering

**Remote Cable Operator  
for Underground Switchgear**

---

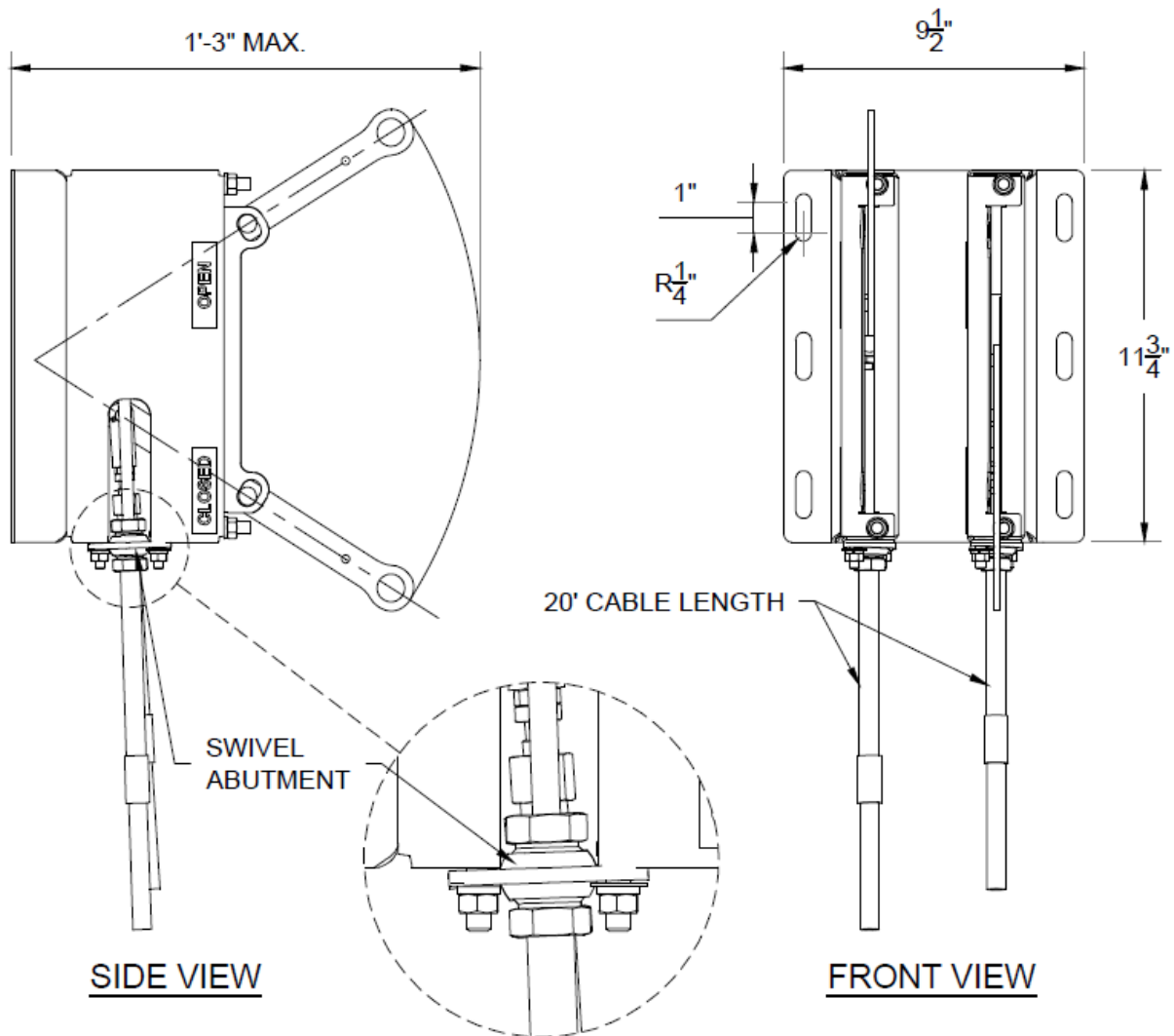

**10. Inspection**

The acceptance of any material or equipment shall in no way relieve the vendor from his responsibility to meet all the requirements of this specification, and it would not prevent subsequent rejection if such materials were found later to be defective.

**11. Warranty**



**Equipment Specification**

Document No.: 4350.314

Item No.: 038-84651

Asset Suite: 84651

Originating Department: Distribution Engineering

**Remote Cable Operator  
for Underground Switchgear**

---

- 11.1. Replacement costs associated with equipment or parts failure due to inadequate design, faulty manufacturing, or packaging are to be the responsibility of the supplier.
- 11.2. In reply to purchaser's request for quotation, supplier shall include the terms and conditions of the warranty period and coverage.
- 11.3. The supplier shall warrant the product against failure while operating under normal conditions.

**12. Proposal Information**

- 12.1. Submitted proposals must include:
  - a. Technical information
  - b. Table of Compliance completed by the bidder with reference. (See Appendix 1)

— End of Specification —



**Equipment Specification**

Document No.: 4350.314

Item No.: 038-84651

Asset Suite: 84651

Originating Department: Distribution Engineering

**Remote Cable Operator  
for Underground Switchgear**

---

**Appendix**



**Equipment Specification**

Document No.: 4350.314

Item No.: 038-84651

Asset Suite: 84651

Originating Department: Distribution Engineering

**Remote Cable Operator  
for Underground Switchgear**

---

**Appendix 1: Table of Compliance**



**Equipment Specification**

Document No.: 4350.314

Item No.: 038-84651

Asset Suite: 84651

Originating Department: Distribution Engineering

**Remote Cable Operator  
for Underground Switchgear**

Line	Criteria	Description	Pass/Fail (P / F)	Comments
1	Specification	The Proponent complies with the corresponding specification document 4350.314.		
2	Industry Standards	The Proponent complies with the industry standards established in the specification document. 4350.314		
3	Material	Stainless Steel 18-8 or 300 series		
4	Product Requirement Product Requirement	The remote cable operator includes: <ul style="list-style-type: none"> <li>• two cable operating handle mounted on a stainless-steel dual cable operator base</li> <li>• two 20' (6.096 m) ball bearing supported flexible control cable with connection brackets and swivel abutments.</li> </ul>		
5		Capable to operate two control cables		
6		Suitable for vertical or horizontal hotstick operation		
7		Padlockable operating handle		
8		The cable operating handle indicates the switch position		
9		The remote cable operator complies with the dimension stated in sections 9.6 to 9.8 and Figure A of the Specification Document 4350.314		
10		Product Requirement	The control cable is a ball bearing supported flexible control cable type	



**Equipment Specification**

Document No.: 4350.314

Item No.: 038-84651

Asset Suite: 84651

Originating Department: Distribution Engineering

**Remote Cable Operator  
for Underground Switchgear**

---

11		The control cable shaft is made of stainless steel and the cable sheath is made of brass or stainless steel.		
12		The control cable ends are furnished with swivel abutment		
13		The control cable is furnished with "L" shape bracket for the switchgear handle connection		
14		The control cable shaft travel is 3 1/2" (8.89 cm) when remote cable operator handle moves from off to on position or vice versa.		











# 4350.314 - Remote Cable Operator for Underground Switchgear

Final Audit Report

2023-09-15

Created:	2023-09-15
By:	Rodolfo Flores (rodolfo.floresortiz@lumapr.com)
Status:	Signed
Transaction ID:	CBJCHBCAABAA9Z10aVT4Dr2vZJES9Nwffd2MIXGsOvgu

## "4350.314 - Remote Cable Operator for Underground Switchgear" History

-  Document created by Rodolfo Flores (rodolfo.floresortiz@lumapr.com)  
2023-09-15 - 8:12:18 PM GMT
-  Document e-signed by Rodolfo Flores (rodolfo.floresortiz@lumapr.com)  
Signature Date: 2023-09-15 - 8:13:57 PM GMT - Time Source: server
-  Document emailed to Rafael Torres-Martinez (rafael.torresm@lumapr.com) for signature  
2023-09-15 - 8:13:58 PM GMT
-  Email viewed by Rafael Torres-Martinez (rafael.torresm@lumapr.com)  
2023-09-15 - 8:16:39 PM GMT
-  Document e-signed by Rafael Torres-Martinez (rafael.torresm@lumapr.com)  
Signature Date: 2023-09-15 - 8:17:25 PM GMT - Time Source: server
-  Document emailed to ricardo.castro@lumapr.com for signature  
2023-09-15 - 8:17:27 PM GMT
-  Email viewed by ricardo.castro@lumapr.com  
2023-09-15 - 8:59:39 PM GMT
-  Signer ricardo.castro@lumapr.com entered name at signing as Ricardo Castro Gómez  
2023-09-15 - 9:00:04 PM GMT
-  Document e-signed by Ricardo Castro Gómez (ricardo.castro@lumapr.com)  
Signature Date: 2023-09-15 - 9:00:06 PM GMT - Time Source: server
-  Agreement completed.  
2023-09-15 - 9:00:06 PM GMT