



Document Title:  
**Manhole with Cover**

Document Type:  
**Specification**

Engineering Type  
**Material Specification**

Document No.:  
**4350.272**

Department  
**Distribution**

Version:  
**01**

Effective Date:  
**Dec 10, 2024**

**Shared document with: N/A**

*\*Select the Departments impacted by the document*

**For others, specify here**

**Author**

Rosalía Alverio González  
Technical Specialist III, Distribution Standards & Materials

Signature

Date

**Dec 6, 2024**

**Reviewer**

Rodolfo Flores Ortiz PE (Lic. 27131)  
General Engineer, Distribution Standards & Materials

Signature

Date

**Dec 6, 2024**

**Approver**

Ricardo Castro Gómez PE (Lic. 12135)  
Manager, Distribution Standards & Materials

Signature

Date

**Dec 10, 2024**

**Management Approval (If apply)**

**Approver**

Name  
Position

Signature and Date

**N/A**

**Related/Referenced Documents**

N/A

**Document History**

Version	Date	Revision Comments
1	December 6, 2024	Initial Release.



## Item Version History

Warehouse Catalog #	Asset Suite #	Version	Date
038-85901	85901	1	12/6/2024
038-52786	52786	1	12/6/2024
038-70153	70153	1	12/6/2024
038-52785	52785	1	12/6/2024
038-52784	52784	1	12/6/2024
038-52788	52788	1	12/6/2024
038-52787	52787	1	12/6/2024
038-01560	56919	1	12/6/2024
038-46718	46718	1	12/6/2024
038-85902	85902	1	12/6/2024

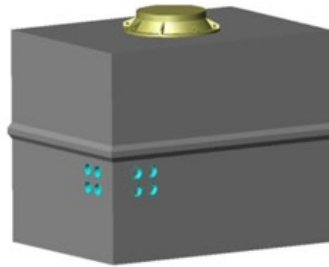

## 1. Introduction

This is a general specification that manhole with cover to be used in the distribution system in Puerto Rico. Further information will be provided by LUMA Energy at the time of order placement and will provide information on site specific conditions, quantity, and other requirements. This document includes the general electrical and mechanical characteristics of the equipment/material.

## 2. Special Requirements

Samples shall be furnished as requested by LUMA Energy. Vendors that have supplied this equipment/material to LUMA on previous orders will not have to furnish samples at bid opening. The equipment/material will be received at the LUMA's general warehouse (011) at Palo Seco, Puerto Rico. Shipping will include transportation and unloading at the indicated warehouse.

## 3. Literature

Descriptive and technical literature must be supplied by the vendor at time of bidding. This literature must include, but is not limited to details of material, drawings, documented testing, and instructions for use and installation. **The literature must be an official document from and certified by the manufacturer.** Failure to submit documents on time and duly certified by the manufacturer will cause bidder disqualification.

## 4. Markings

- 4.1. Containers shall be marked outside with LUMA Energy's purchase order and item number.
- 4.2. Package(s) to be delivered at warehouse shall be clearly marked with manufacturer and item information (part number, serial number, quantity, etc.).
- 4.3. Packaging labels and tags shall be waterproof.

## 5. Packaging

All material and equipment shall be packaged and marked in such a way as to facilitate handling and protection from damage and that the receiving warehouse can readily identify it and send it, in one complete unit, to a field location without opening crates or boxes to sort items and/or parts.

## 6. Number Per Package (Logistics)

Each manufacturer shall define the number of manholes per packages depending on the shipping containers and platforms for delivery or as requested by LUMA.

## 7. Acceptance Criteria

7.1. Product shall be manufactured in accordance with the latest issue below (section 7.2). When conflicts occur between purchaser's specifications and the latest issue below, the purchaser's specification shall prevail.

7.2. Latest applicable codes, standards, and other regulations:

ACI American Concrete Institute

ANSI American National Standards Institute

ASCE American Society of Civil Engineers

ASTM American Society for Testing and Materials

AWS American Welding Society

NESC National Electrical Safety Code

IEEE Institute of Electrical and Electronic Engineers

PCI Prestressed Concrete Institute

7.3. If any other standard different from the ones indicated in this document are used, the supplier must provide information showing compatibility with the required ones.

## 8. Description

This specification is for the purpose of the manhole with cover support the electrical distribution system. The specifications are divided into two parts in the Technical Specifications and the Special Conditions. The Technical Specifications will include the material, design, drawings, final approval before manufacture, and failure to meet guarantees. The Special Conditions will include the requirements, descriptions, and delivery of material.

## 8.1. The Technical Specifications

### a. **Material**

Main structure concrete shall be in accordance to American Society for Testing and Material (ASTM), and other Standards and regulations. All material used to fabricate the structure in this specification shall be properly certified by the manufacturers.

### b. **Design**

The supplier is responsible of the design. The bidder will have to deliver the final computations, and all design parameters considered. If the design was performed by a computer program, submit runs of the program.

### c. **Drawings**

Drawing for the bid proposal at PDF format shall include with the following information:

1. General dimensions of all the structural components.
2. Weight for each manhole.
3. A bill of materials.
4. Details of all accessories.

### d. **Final Approval before Manufacture**

1. Final design calculations shall be submitted before fabrication commences together with the shop drawing for LUMA approval.
2. After approval, a set of drawings and design calculations at PDF format. All drawings shall include our purchase order number.

### e. **Failure to Meet Guarantees**

Should any piece of equipment fail to meet the guarantees and the requirements of these specifications within the time covered by the guarantee, it shall be optional to the Engineer to accept the manhole or reject it and direct the manufacturer to at once proceed to make alterations or furnish such new parts as may be necessary to make it meet the guarantees and requirements. All expense of furnishing and installing new parts by failure of the manhole to meet the guarantees and other requirements of the specifications will be manufacturer's responsibility.

## 8.2. Special Conditions:

### a. **The Requirements**

The manufacturer shall submit drawings of each individual design for evaluation and approval:

1. Manhole (10'x 7'x 8') with Round Cover (31-9/16") –**Appendix 1.**

2. Manhole (10'x7'x8') with Rectangular Double Door Cover (9'-8" x 5') –**Appendix 2.**
3. Manhole (12'x 6'x 8') with Rectangular Cover including: (4) Four Rail Covers: 5'x1'-9" and (4) Four Solid Cover: 5'x18-1/4" –**Appendix 3.**
4. Manhole (12'x 9'x 8') with Round Cover (43 3/4") –**Appendix 4.**
5. Manhole (12'x 9'x 8') with Rectangular Double Door Hatch Cover (8'-8"x 5'-2"x5") – **Appendix 5.**

**b. Description:**

1. DT93 Dual Hatch:
  - a. The heavy-duty angle type floor access hatch must be designed for exterior applications and direct traffic rated conforming AASHTO HL93 wheel loads.
  - b. The floor access hatch shall be equal or similar to model DT93-AHD manufactured by U.S.F. Fabrication, Inc.
  - c. Floor access hatches dimensions and configuration must be as per corresponding LUMA standard.
  - d. Covers shall be 3/8 in. thick steel diamond plate reinforced for an AASHTO HL93 wheel load (ASTM C1802-14 Load Level 7). Upon request, manufacturer shall provide structural calculations, stamped by a registered professional engineer, which certify that the hatch design meets the requirements of AASHTO HL93.
  - e. The frame shall be 1/2 in. thick steel angle with anchors welded to frame for casting into concrete.
  - f. In the closed position the covers shall be bolted to the frame with 316 stainless steel Allen-Head bolts to allow for HL93 direct traffic loading—an Allen-Head wrench will be provided with the hatch.
  - g. The Allen-Head bolts must be securely fastened using heavy duty thread-locking fluid whenever the covers are closed to insure safe and proper performance of the hatch.
  - h. For security covers shall have a recessed staple for a padlock.
  - i. The floor access hatch shall be equipped with flush steel lifting handles that do not protrude above the covers and hold open arms that automatically keep the covers in their upright open positions.
  - j. A steel skirt shall be welded to the frame to provide a combined height equal to the depth of the concrete slab.
  - k. The hatch shall have tamper resistant hinges with recessed stainless-steel pins and lugs.



- h. The frame shall be steel angle with anchors welded to frame for casting into concrete.
- i. For security covers shall have a recessed staple for a padlock.
- j. The steel cover shall be equipped with flush steel lifting handles that do not protrude above the covers.
- k. The installation of steel cover and frame shall be in accordance with the manufacturer's attached instructions.
- l. The entire frame, including the seat on which the reinforcing rests, shall be supported by concrete or other material designed to support the specified load.
- m. The manufacturer shall guarantee the steel cover and frame against defects in materials and workmanship for a period of five (5) years.

**c. Delivery of material:**

- 1. The distribution manhole will be delivered at the LUMA General Warehouse in Palo Seco (011), Puerto Rico, unless otherwise indicated and coordinated in another area provided by the company.
- 2. LUMA may take delivery at a designated location with the delivering carrier's equipment. The manufacturer shall coordinate with LUMA to ensure a smooth and efficient delivery of the manhole.
- 3. LUMA shall provide all labor, equipment, and materials for unloading the manhole at the project site. A manhole is considered delivered when it is lifted from the delivery carrier's trailer or semi-trailer.

**9. Concrete Mixes**

- 9.1. Concrete Mixes Concrete mixes shall be proportioned to produce the strength, durability and workability required by the approved mix design. The manufacturer shall submit his proposed mix designs to LUMA for approval at least six weeks before the manufacturer is due to commence. LUMA may direct the manufacturer to undertake trial mixes and strength, durability, and workability tests to prove that the proposed mixes are acceptable. Such trial mixes and tests shall be carried out prior to placement of concrete in the works and their costs shall be borne by the manufacturer. Unless otherwise specified or approved by LUMA, concrete shall have the following properties:
- a. Maximum Water Cement Ratio by Weight: 0.40
  - b. The minimum characteristic compressive strength for Prestressed F 'c at 28 days shall be equal to all bases 4,000 psi.

- 9.2. The manufacturer shall keep at the mixing site, records showing for each batch of concrete produced, the time and date of water addition, the weight of cement, weight of each grade of aggregate, weight of added water, results of tests made to determine the water contained in the aggregate, the results of any strength tests and the location of concrete in the works. These records shall be made available to LUMA.
- 9.3. The proportions of aggregate and cement for any concrete shall be such as to produce a mix which will work readily into corners and angles of the forms and around tendons and reinforcement with the method of placing employed on the work, but without permitting the materials to segregate or water to collect on the surface.
- 9.4. Water shall be accurately measured by a calibrated tank or by an approved type of calibrated water meter attached to the mixer. Certification of water meter calibration shall be supplied to LUMA upon request.
- 9.5. Mixing shall be by an efficient type of batch mixer operated at the speeds recommended by the manufacturer with particular regard to the use of low slump concrete. All concrete shall be mixed for a period of not less than 2 minutes after all materials including water are placed in the mixer.
- 9.6. No concrete that has reached its initial set (partially hardened) or that has left the mixer or agitator for more than 30 minutes shall be placed in the structure. Remixing shall not be permitted.
- 9.7. Ready-mixed concrete complying with ASTM C94 - Ready Mixed Concrete and the requirements of this Specification, whether manufactured in a plant operated by the manufacturer or approved Subcontractors, may be used.

## **10. Formwork**

- 10.1. All forms shall be built mortar-tight, of sufficient rigidity and adequately supported to prevent distortion or displacement due to the pressure of the concrete and other loads incidental to the construction operations. Forms shall be constructed and maintained to prevent warping and the opening of joints due to shrinkage of the timber.
- 10.2. Forms shall be built with provision for easy inspection and cleaning out immediately before concrete is placed.
- 10.3. A high standard of finish is required, and surfaces of precast, spun, and prestressed concrete members shall be true, hard, smooth, and free from any defects due to leakage of mortar from the molds.
- 10.4. Molds should preferably be made of steel.
- 10.5. Every care shall be taken to ensure that no marks or fins appear on the finished surface.
- 10.6. The inside of forms shall be thoroughly wetted or coated with non-staining form release oil or other approved material. Where oil or surfacing material is used, it shall be applied before the reinforcement is placed.

- 10.7. When forms have become warped, damaged, or burred so that in the opinion of the Superintendent the surface or dimensional tolerances of the concrete will not be satisfactory, the manufacturer shall, when so directed by LUMA, remove such forms, and replace them with forms or form panels satisfactory in all respects.
- 10.8. Forms shall be removed so as not to damage the concrete.

## **11. Placing of Reinforcement**

- 11.1. Steel shall be free from all loose rust, grease, tar, paint, oil, mud, mill scale or other coating which would tend to destroy its bond with the concrete. All reinforcing bars shall be bent as shown on the Drawings and shall be placed accurately and be well secured by tie wiring or welding were permitted so that no displacement can occur during placing of concrete. The specified clear cover shall be maintained. Tie wire of at least 18 s.w.g. soft iron wire shall be bent inwards or cut off.
- 11.2. Care shall be taken to ensure that the cage is correctly aligned and positioned in relation to the through-bolt holes, ferrules, and the pole axis, and that the cage reinforcement is not spirally deformed or displaced.
- 11.3. Bending and splicing of reinforcing shall be carried out as required by ASTM. Splices shall be of length sufficient to fully develop the capacity of the bars.
- 11.4. All prestressing tendons shall be accurately located and restrained in position. No welding will be permitted in close proximity to any prestressing tendon without suitable shielding.
- 11.5. Prestressing tendons, where supplied in coils, shall be of large enough diameter to be self-straightening. Kinked or damaged tendons will not be permitted.
- 11.6. Prestressing steel shall not be welded and shall be flame cut only with the approval of the LUMA.

## **12. Inspection**

The acceptance of any equipment/material shall in no way relieve the vendor from his responsibility to meet all the requirements of this specification, and it would not prevent subsequent rejection if such equipment/materials were found later to be defective.

## **13. Proposal Information**

- 13.1. Submitted proposals must include:
  - a. Technical information, tests, and drawings.
  - b. Table of Compliance completed by the bidder with reference. (See Appendix 1)



#### 14. Table 1: Warehouse and Asset Suite Identification Number

Item	Description	Warehouse Number	Asset Suite
1	Manhole (10'x 7'x 8') with Round Cover (31-9/16")	038-85901	85901
2	Round Cover (31-9/16")	038-52786	52786
3	Manhole (10'x7'x8') with Rectangular Double Door Cover (9'-8" x 5')	038-70153	70153
4	Rectangular Double Door Cover (9'-8" x 5')	038-52785	52785
5	Manhole (12'x 6'x 8') with Rectangular Cover including: (4) Four Rail Covers: 5'x1'-9" and (4) Four Solid Cover: 5'x18-1/4"	038-52784	52784
6	Rectangular Cover including: (4) Four Rail Covers: 5'x1'-9" and (4) Four Solid Cover: 5'x18-1/4"	038-52788	52788
7	Manhole (12'x 9'x 8') with Round Cover (43 3/4")	038-52787	52787
8	Round Cover (43 3/4")	038-01560	56919
9	Manhole (12'x 9'x 8') with Rectangular Double Door Hatch Cover (8'-8"x 5'-2")	038-46718	46718
10	Rectangular Double Door Hatch Cover (8'-8"x 5'-2"x5")	038-85902	85902

— End of Specification —



## Appendix



**Appendix 2: Table of Compliance:**

Line	Criteria	Description	Pass/Fail (P/F)	Comments
1	Specification	The Proponent complies with the corresponding specification document (4350.272)		
2	Industry Standards	The Proponent complies with the industry standards established in the specification document. (ACI, ANSI, ASTM, AWS, NESC, IEEE, PCI)		
3	Dimensions Manhole	Manhole (10'x 7'x 8') with Round Cover (31-9/16")		
		Manhole (10'x7'x8') with Rectangular Double Door Cover (9'-8" x 5')		
		Manhole (12'x 6'x 8') with Rectangular Cover including: (4) Four Rail Covers: 5'x1'-9" and (4) Four Solid Cover: 5'x18-1/4"		
		Manhole (12'x 9'x 8') with Round Cover (43 3/4")		
		Manhole (12'x 9'x 8') with Rectangular Double Door Hatch Cover (8'-8"x 5'-2")		
4	Dimensions Cover	Round Cover (31-9/16")		
		Rectangular Double Door Cover (9'-8" x 5')		
		Rectangular Cover including: (4) Four Rail Covers: 5'x1'-9" and (4) Four Solid Cover: 5'x18-1/4"		
		Round Cover (43 3/4")		
		Rectangular Double Door Hatch Cover (8'-8"x 5'-2"x5")		

**NOTE: This table is only a checklist for reference. The compliance shall be with the complete document. Marking a PASS in the table won't be accepted as a compliance without the technical information required to certify it.**



# DISTRIBUTION STANDARDS AND MATERIALS

TITLE:

MANHOLE 10'-0" X 7'-0" X 8'-0"  
WITH ROUND COVER 31-9/16"

APPENDIX NO. 1  
DOCUMENT NO. 4350.272  
PAGE 1 OF 1 DATE DIC 05, 2024  
SUBMITTED ROSALIA ALVERIO GONZALEZ  
REVIEWED RICARDO CASTRO LIC. 12135  
APPROVED RICARDO CASTRO LIC. 12135  
DIGITIZED VICTOR R. FEBRES LIC. 3412

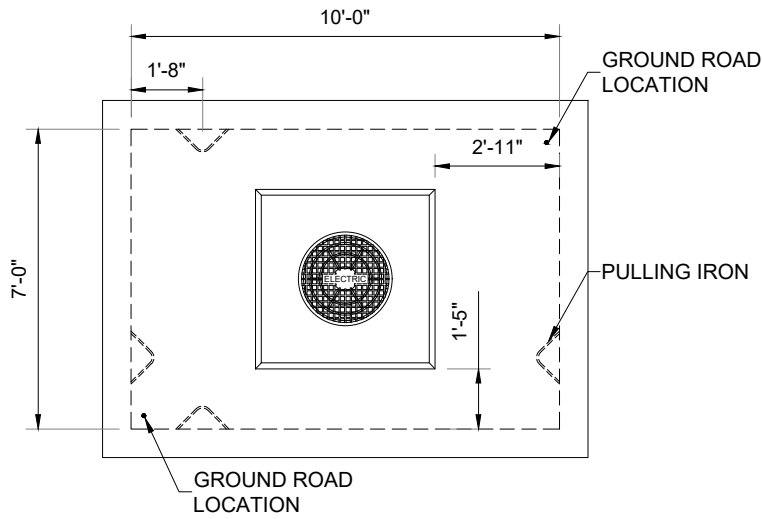

TOP VIEW

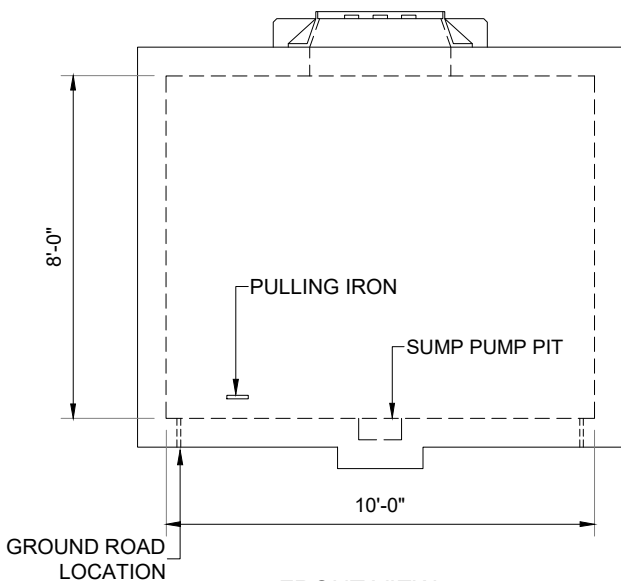
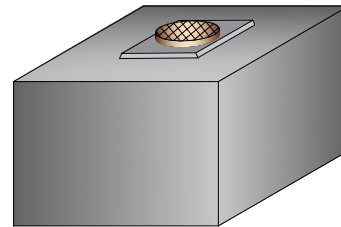

FRONT VIEW

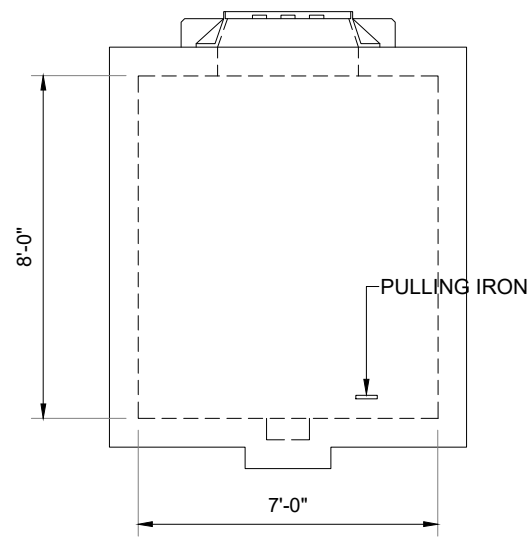

SIDE VIEW



# DISTRIBUTION STANDARDS AND MATERIALS

TITLE:

MANHOLE 10'-0" X 7'-0" X 8'-0" WITH  
DOUBLE DOOR COVER 9'-8" X 5'-0"

APPENDIX NO. 2  
DOCUMENT NO. 4350.272  
PAGE 1 OF 1 DATE DIC 05, 2024  
SUBMITTED ROSALIA ALVERIO GONZALEZ  
REVIEWED RICARDO CASTRO LIC. 12135  
APPROVED RICARDO CASTRO LIC. 12135  
DIGITIZED VICTOR R. FEBRES LIC. 3412

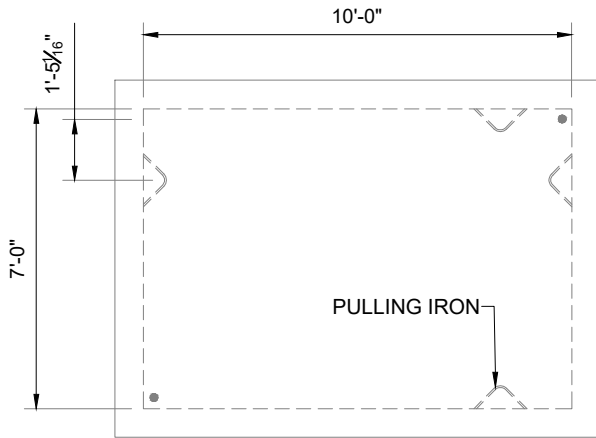

TOP VIEW

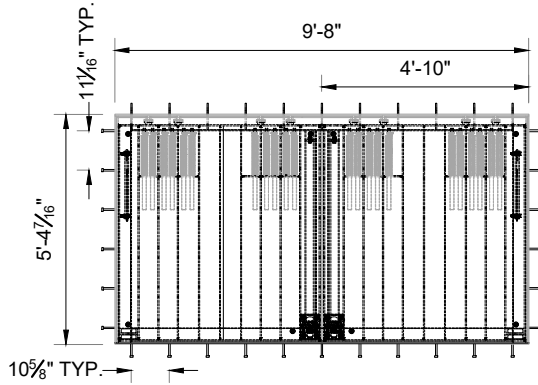

MANHOLE COVER PROTECTION

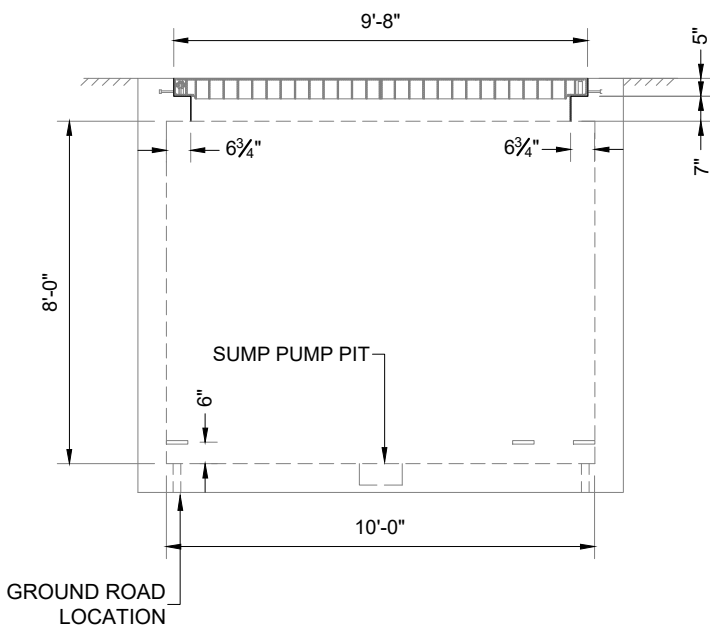

FRONT VIEW

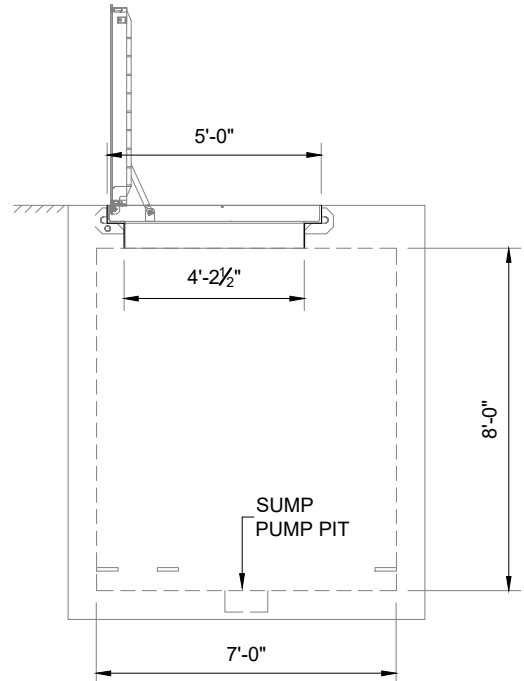

SIDE VIEW



# DISTRIBUTION STANDARDS AND MATERIALS

TITLE:

MANHOLE 12'-0" X 6'-0" X 8'-0" WITH  
RECTANGULAR COVER 12'-5" X 5' X 3 1/4"

APPENDIX NO. 3  
DOCUMENT NO. 4350.272  
PAGE 1 OF 1 DATE DIC 05, 2024  
SUBMITTED ROSALIA ALVERIO GONZALEZ  
REVIEWED RICARDO CASTRO LIC. 12135  
APPROVED RICARDO CASTRO LIC. 12135  
DIGITIZED VICTOR R. FEBRES LIC. 3412

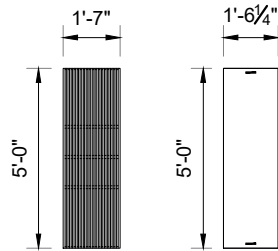

RECTANGULAR COVER

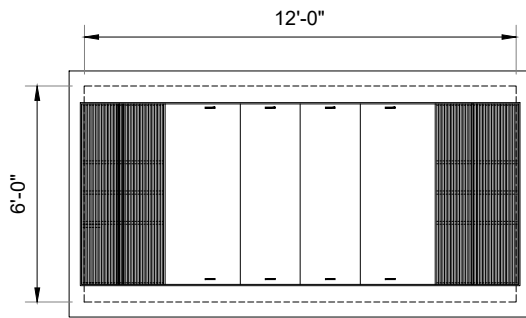

TOP VIEW

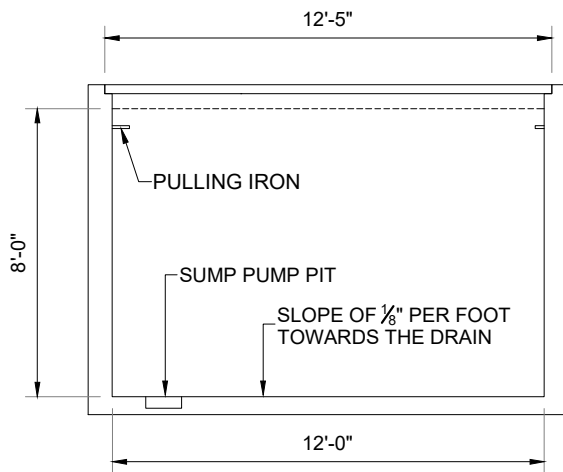
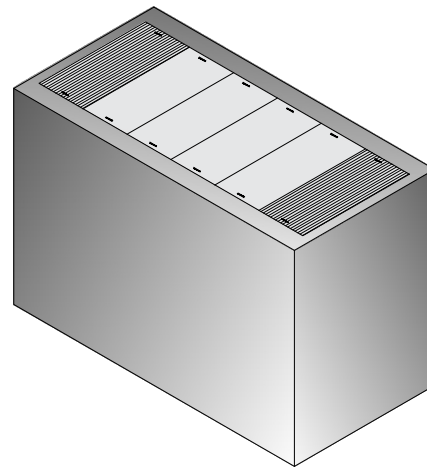

FRONT VIEW

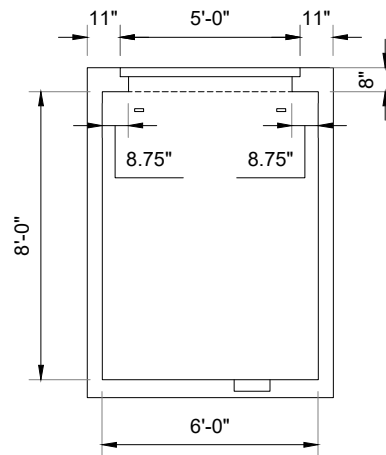

SIDE VIEW



# DISTRIBUTION STANDARDS AND MATERIALS

TITLE:

MANHOLE 12'-0" X 9'-0" X 8'-0"  
WITH ROUND COVER 8" X 43<sup>3</sup>/<sub>4</sub>"

APPENDIX NO. 4  
DOCUMENT NO. 4350.272  
PAGE 1 OF 1 DATE DIC 05, 2024  
SUBMITTED ROSALIA ALVERIO GONZALEZ  
REVIEWED RICARDO CASTRO LIC. 12135  
APPROVED RICARDO CASTRO LIC. 12135  
DIGITIZED VICTOR R. FEBRES LIC. 3412

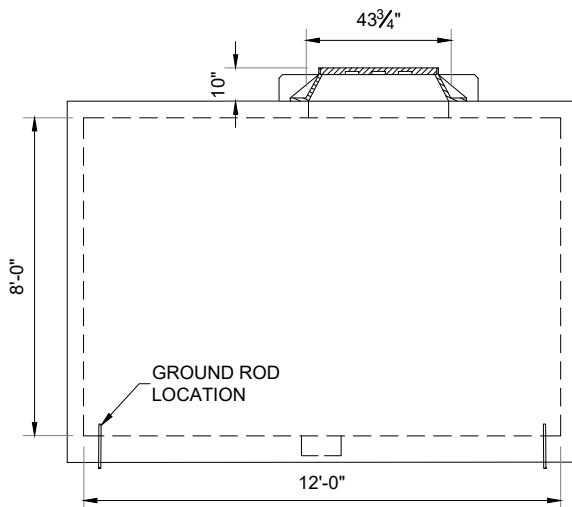
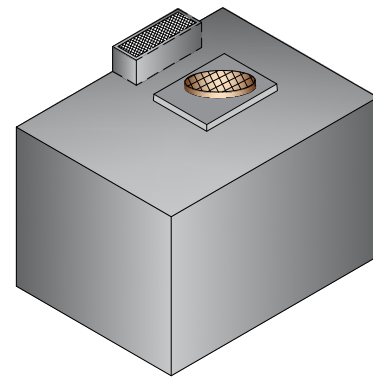
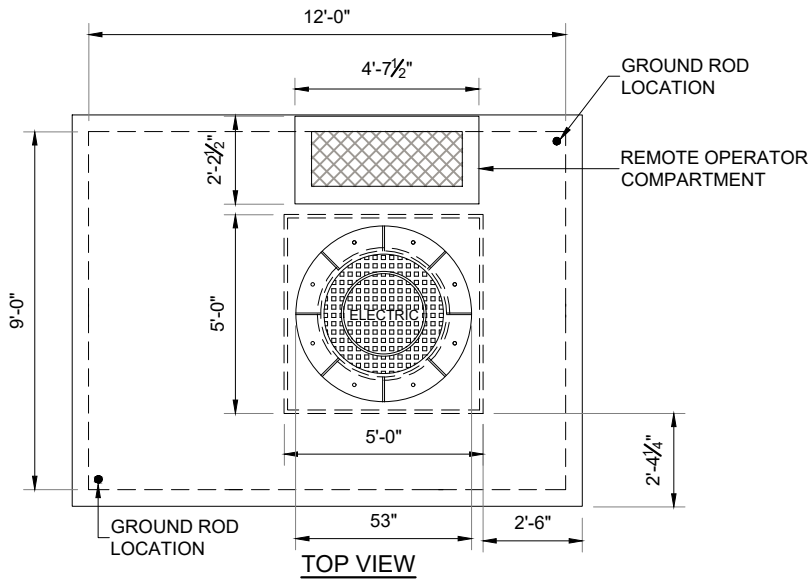

FRONT VIEW

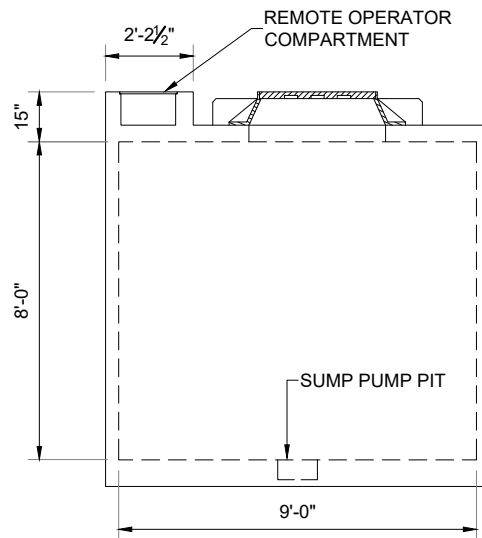

SIDE VIEW



# DISTRIBUTION STANDARDS AND MATERIALS

TITLE:

MANHOLE 12'-0" X 9'-0" X 8'-0" WITH  
RECTANGULAR DOUBLE DOOR COVER 8'-8" X 5'-2" X 5"

APPENDIX NO. 5  
DOCUMENT NO. 4350.272  
PAGE 1 OF 1 DATE DIC 05, 2024  
SUBMITTED ROSALIA ALVERIO GONZALEZ  
REVIEWED RICARDO CASTRO LIC. 12135  
APPROVED RICARDO CASTRO LIC. 12135  
DIGITIZED VICTOR R. FEBRES LIC. 3412

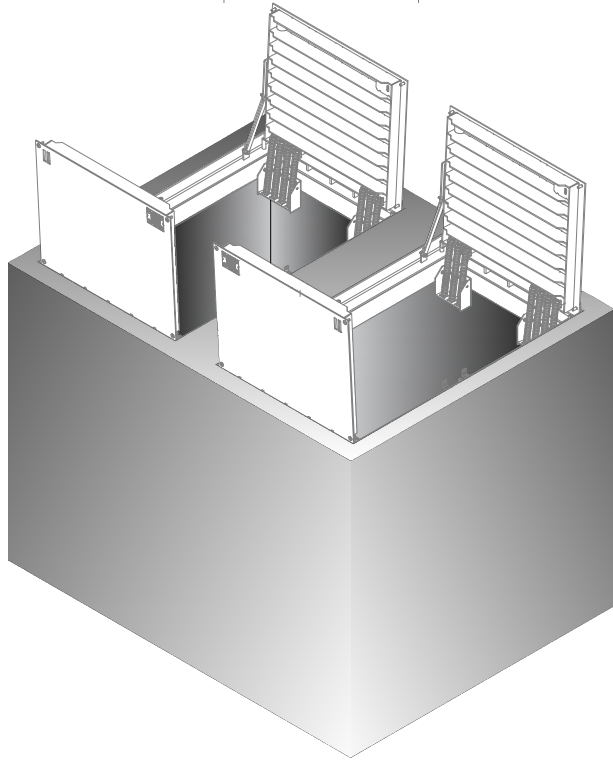
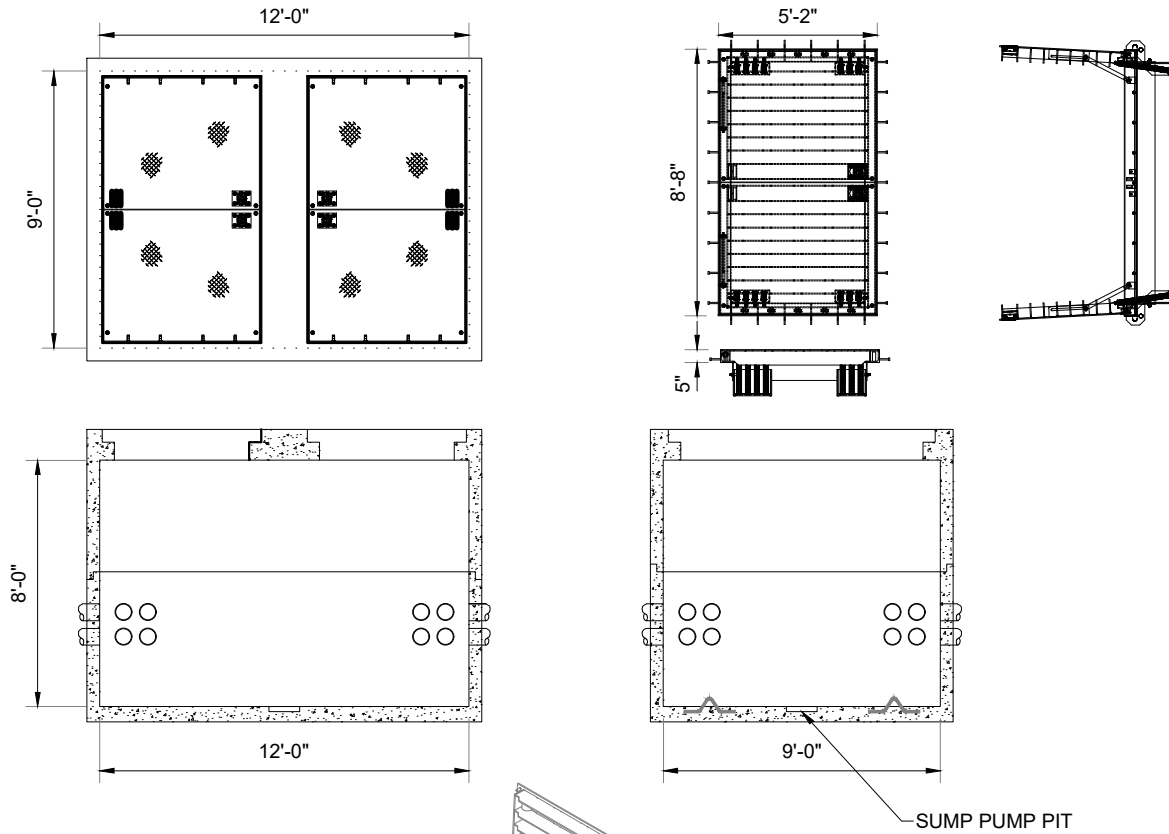











# 4350.272 Manhole with Cover (12-6-2024)

Final Audit Report

2024-12-10

Created:	2024-12-06
By:	Rosalia Alverio (rosalia.alverio@lumapr.com)
Status:	Signed
Transaction ID:	CBJCHBCAABAA1dYF4zO5VFe90D20j5_mZhOnG7BrJesQ

## "4350.272 Manhole with Cover (12-6-2024)" History

-  Document created by Rosalia Alverio (rosalia.alverio@lumapr.com)  
2024-12-06 - 8:33:06 PM GMT
-  Document emailed to Rosalia Alverio (rosalia.alverio@lumapr.com) for signature  
2024-12-06 - 8:33:15 PM GMT
-  Document emailed to Rodolfo Flores (rodolfo.floresortiz@lumapr.com) for signature  
2024-12-06 - 8:33:15 PM GMT
-  Document emailed to Ricardo Castro (ricardo.castro@lumapr.com) for signature  
2024-12-06 - 8:33:15 PM GMT
-  Email viewed by Rosalia Alverio (rosalia.alverio@lumapr.com)  
2024-12-06 - 8:33:43 PM GMT
-  Document e-signed by Rosalia Alverio (rosalia.alverio@lumapr.com)  
Signature Date: 2024-12-06 - 8:34:16 PM GMT - Time Source: server
-  Email viewed by Rodolfo Flores (rodolfo.floresortiz@lumapr.com)  
2024-12-06 - 8:36:05 PM GMT
-  Document e-signed by Rodolfo Flores (rodolfo.floresortiz@lumapr.com)  
Signature Date: 2024-12-06 - 9:01:54 PM GMT - Time Source: server
-  Email viewed by Ricardo Castro (ricardo.castro@lumapr.com)  
2024-12-10 - 5:27:55 PM GMT
-  Document e-signed by Ricardo Castro (ricardo.castro@lumapr.com)  
Signature Date: 2024-12-10 - 5:28:57 PM GMT - Time Source: server
-  Agreement completed.  
2024-12-10 - 5:28:57 PM GMT