



Document Title:

Hexagonal Nuts, Stainless Steel 316

Document Type:

Material Specifications

Document No.:

4350.114

Department:

Distribution Standards & Materials

Version:

2

Effective Date:

Aug 31, 2023

Shared documents: T&S T&D T&TM D&TM Luma Engineering

Author Miguel J. Rios López, PE General Engineer, Distribution Standards & Materials	Signature 	Date Aug 31, 2023
Reviewer Rene Maldonado, PE Supervisor, Line Engineering Standards	Signature Rene Maldonado (Aug 31, 2023 14:10 EDT)	Date Aug 31, 2023
Reviewer Rafael Torres Martinez PE Supervisor, Distribution Standards & Materials	Signature 	Date Aug 31, 2023
Approver Ricardo Castro Gómez, PE Manager, Distribution Standards & Materials	Signature 	Date Aug 31, 2023

Document History

Date	Revision Comments
Jan. 20, 2022	Initial Release with item 002-82038. (Ver. 1)
Mar. 18, 2022	General format modifications (Sections 3, 4, and 7). Table of Compliance (TOC) added. (Ver. 2)
Mar. 30, 2023	Items 002-84574 and 002-84575 created. Cover Page and Table 1 added. TOC and Section 9 modified. Document name modified.
Jun. 01, 2023	New Item added (002-84871). Table 1 and TOC modified. Grainger model for item 002-84575 corrected. Figure 1 added for reference for all items.
Aug. 31, 2023	General format modifications. Document changed as shared between T&D for Item 002-82038.

Items	Warehouse Catalog#	Version	Date
1	* 002-82038	5	8/31/2023
2	002-84574	3	8/31/2023
3	002-84575	3	8/31/2023
4	002-84871	2	8/31/2023



Hexagonal Nuts, Stainless Steel 316

1. Introduction

This is a general specification that covers the minimum requirements for stainless steel hexagonal nuts used in the distribution and transmission system in Puerto Rico. Further information will be provided by LUMA Energy at the time of order placement and will provide information on site specific conditions, quantity, and other requirements. This document includes the general electrical and mechanical characteristics of the equipment/material.

2. Special Requirements

Samples shall be furnished as requested by LUMA Energy. Vendors that have supplied this equipment/material to LUMA on previous orders will not have to furnish samples at bid opening. The equipment/material will be received at the LUMA's general warehouse (011) at Palo Seco, Puerto Rico. Shipping will include transportation and unloading at the indicated warehouse.

3. Literature

Descriptive and technical literature must be supplied by the vendor at time of bidding. This literature may include, but is not limited to details of material, drawings, documented testing, and instructions for use and installation. Failure to submit documents on time will cause bidder disqualification. For products described in this specification as requiring qualification, awards will be made only for such products that, prior to the time for opening of bids, had been tested and/or approved by LUMA Energy. Evidence of LUMA Energy's approval of the equipment/material shall be supplied by the vendor if requested by LUMA Energy.

4. Markings

- 4.1. Packages shall be marked outside with LUMA Energy's purchase order and item number.
- 4.2. Packaging labels and tags shall be waterproof.

5. Compatible with

- 5.1 For compatible manufacturer and model see Table 1.
- 5.2 These models are examples of the equipment/material described in this document and do not represent a preference. LUMA will evaluate equally any model not listed here during any acquisition event.

Hexagonal Nuts, Stainless Steel 316

6. Packaging

All equipment/material shall be packaged and marked in such a way as to facilitate handling and protection from damage and that the receiving warehouse can readily identify it and send it, in one complete unit, to a field location without opening crates or boxes to sort items and/or parts.

7. Number Per Package (Logistics)

7.1. Standard package: as per Table 1 or as requested by LUMA Energy.

8. Acceptance Criteria

8.1. Test required: certified by external laboratories.

8.2. Latest applicable codes, standards, and other regulations:

- a. ASME B18.2.2: Standard for the complete general and dimensional data for the various types of inch series square and hex nuts, including machine screw nuts and coupling nuts.
- b. ASTM F594 (18-8): Standard specification for stainless steel nuts.
- c. ASME B1.1, UNC, UNF and UNS, class 2B: Standard for the thread form, series, class, allowance, tolerance, and designation for unified screw threads.
- d. ASTM A380/A380M: Standard practice for cleaning, descaling, and passivation of stainless-steel parts, equipment, and systems.

9. Description

9.1. Stainless steel hexagonal nuts are to be used on mechanical connections with stainless-steel bolts.

9.2. Material: Stainless Steel 316

9.3. Thread Count (TPI) as per Table 1.

9.4. Thickness and Wrench size as per Table 1 and Figure 1.

10. Inspection

The acceptance of any equipment/material shall in no way relieve the vendor from his responsibility to meet all the requirements of this specification, and it would not prevent subsequent rejection if such equipment/materials were found later to be defective.

11. Proposal Information

11.1. Submitted proposals must include:

- a. Technical information
- b. Table of Compliance completed by the bidder with reference (see Appendix 1).

Hexagonal Nuts, Stainless Steel 316

12. Table 1: Warehouse and Asset Suite Identification Number

Warehouse Catalog #	Asset Suite #	Diameter and Thread Size	Thickness	Wrench Size	Package	Compatible Manufacturer & Model
* 002-82038	82038	1/2" - 13 TPI	0.437" (11.1 mm)	3/4" (19.0 mm)	25 ea.	Grainger (Item 45NZ83) Fastenal (77714)
002-84574	84574	5/8" - 11 TPI	0.547" (13.9 mm)	15/16" (23.8 mm)	25 ea.	Grainger (Item 45NZ84) Fastenal (77716)
002-84575	84575	3/4" - 10 TPI	0.656" (16.7 mm)	1-1/8" (28.6 mm)	20 ea.	Grainger (Item 45NZ85) Fastenal (77717)
002-84871	84871	3/8" - 16 TPI	0.328" (8.3 mm)	9/16" (14.3 mm)	50 ea.	Grainger (Item 45NZ81) Fastenal (77712)

* Item 002-82038 is also used in the 38kV transmission system

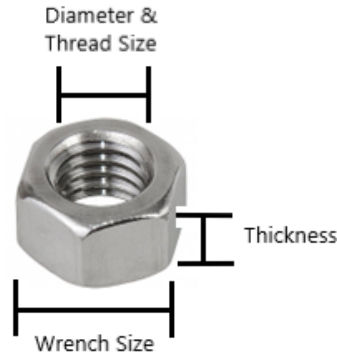

Figure 1

— End of Specification —

Document No.: 4350.114

Originating Department: Distribution Engineering

Hexagonal Nuts, Stainless Steel 316

Appendix

Hexagonal Nuts, Stainless Steel 316

Appendix 1: Table of Compliance

Line	Criteria	Description	Pass/Fail (P/F)	Comments
1	Specification	The Proponent complies with the corresponding specification document (4350.114).		
2	Industry Standards	The Proponent complies with the industry standards established in the specification document (ASTM, ASME).		
3	Material	Stainless Steel 316		
4	Thickness	<ul style="list-style-type: none"> • 002-82038: 0.437" • 002-84574: 0.547" • 002-84575: 0.656" • 002-84871: 0.328" 		
5	Wrench Size	<ul style="list-style-type: none"> • 002-82038: 3/4" • 002-84574: 15/16" • 002-84575: 1-1/8" • 002-84871: 9/16" 		
6	Bolt Diameter & Threads per inch	<ul style="list-style-type: none"> • 002-82038: 1/2" X 13 TPI • 002-84574: 5/8" X 11 TPI • 002-84575: 3/4" X 10 TPI • 002-84871: 3/8" X 16 TPI 		











4350.114 Hex Nuts, SS (8-31-23)

Final Audit Report

2023-08-31

Created:	2023-08-31
By:	Wanda Ocasio (wanda.ocasio@lumapr.com)
Status:	Signed
Transaction ID:	CBJCHBCAABAAAdV8Z0UxOhae4KgVJujjbCarofvcMyFcf

"4350.114 Hex Nuts, SS (8-31-23)" History

-  Document created by Wanda Ocasio (wanda.ocasio@lumapr.com)
2023-08-31 - 5:55:16 PM GMT
-  Document emailed to Miguel Rios (miguel.rioslopez@lumapr.com) for signature
2023-08-31 - 5:57:22 PM GMT
-  Email viewed by Miguel Rios (miguel.rioslopez@lumapr.com)
2023-08-31 - 5:58:29 PM GMT
-  Document e-signed by Miguel Rios (miguel.rioslopez@lumapr.com)
Signature Date: 2023-08-31 - 5:58:39 PM GMT - Time Source: server
-  Document emailed to Rene Maldonado (rene.maldonado@lumapr.com) for signature
2023-08-31 - 5:58:40 PM GMT
-  Email viewed by Rene Maldonado (rene.maldonado@lumapr.com)
2023-08-31 - 6:10:26 PM GMT
-  Document e-signed by Rene Maldonado (rene.maldonado@lumapr.com)
Signature Date: 2023-08-31 - 6:10:31 PM GMT - Time Source: server
-  Document emailed to Rafael Torres-Martinez (rafael.torresm@lumapr.com) for signature
2023-08-31 - 6:10:32 PM GMT
-  Email viewed by Rafael Torres-Martinez (rafael.torresm@lumapr.com)
2023-08-31 - 6:45:14 PM GMT
-  Document e-signed by Rafael Torres-Martinez (rafael.torresm@lumapr.com)
Signature Date: 2023-08-31 - 6:45:36 PM GMT - Time Source: server
-  Document emailed to ricardo.castro@lumapr.com for signature
2023-08-31 - 6:45:37 PM GMT

 Email viewed by ricardo.castro@lumapr.com

2023-08-31 - 8:52:48 PM GMT

 Signer ricardo.castro@lumapr.com entered name at signing as Ricardo Castro Gómez

2023-08-31 - 8:53:12 PM GMT

 Document e-signed by Ricardo Castro Gómez (ricardo.castro@lumapr.com)

Signature Date: 2023-08-31 - 8:53:14 PM GMT - Time Source: server

 Agreement completed.

2023-08-31 - 8:53:14 PM GMT